

Accessories for Ex9A and Ex9ASD



- Internal and functional accessories for the air circuit breaker and switch disconnecter
- Installation accessories intended to ease up the electrical / mechanical connection of the breaker to the system
- Extension of functionalities for tripping units

The accessories of the ACB series Ex9A and switch disconnecter series Ex9ASD are products that improve the characteristics, functionalities and the installation flexibility of the breakers to make them suitable for any kind of application. The accessories are divided into the following categories:

Internal / functional accessories: Accessories that are intended to increment the functionality of the circuit breaker. They add additional control features to the breaker, for example: SHT, UVTR, MD, AX etc.

Installation accessories: Accessories intended to ease or improve the suitability of the breaker to any electrical installation, this category is grouping the following accessories among others: RCP main terminals, TEX Extension terminals with screaders, ACP front terminals, PHS/DPS phase barriers, PIA mechanical interlocks etc.

Software accessories: Accessories preloaded into the smart unit to provide additional protecting and analyzing features to the smart unit. They are for example: WEC earth wire current transformer, LEC leakage differential transformer, ZSI Zone selective interlock, COM Modbus, DI/DO programmable digital inputs and outputs etc.

Type Key

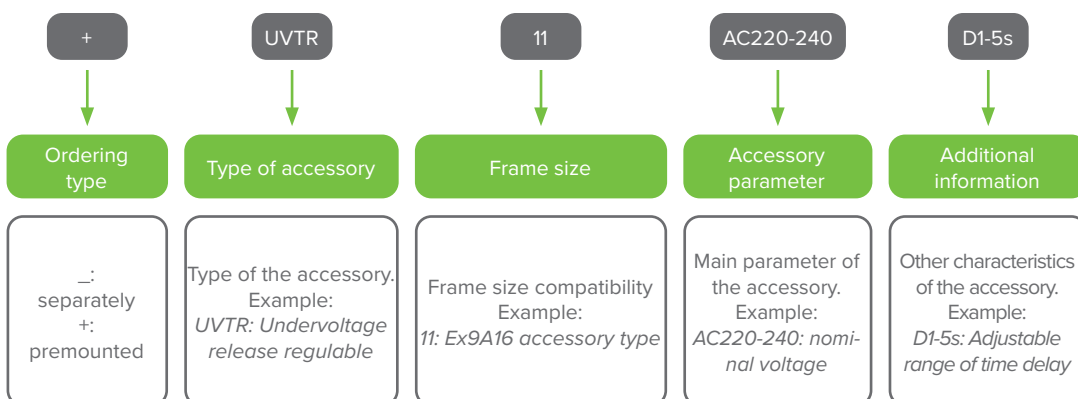

Certification marks



Ex9A and SU Accessories distribution

Distribution map of Ex9A accessories

Ex9A frame size		Ex9A16 (11)		Ex9A25 (12)		Ex9A32 (13)		Ex9A40 (14)	
Accessory		Fixed	Withdra- wable	Fixed	Withdra- wable	Fixed	Withdra- wable	Fixed	Withdra- wable
Auxiliary contacts AX	separately	AX11 44 AX11 66		AX12 44 AX12 66					
	premounted	+AX11 44 +AX11 66		+AX12 44 +AX12 66					
Shunt trip release SHT (remote OFF)	separately	SHT 11 AC380-415V SHT 11 AC220-240/DC220V SHT 11 DC48~60V SHT 11 DC24V SHT 11 AC380-415V D SHT 11 AC220-240/DC220V D SHT 11 AC/DC110V D		SHT 12 AC380-415V SHT 12 AC220-240/DC220V SHT 12 AC/DC110V					
	premounted	+SHT 11 AC380-415V +SHT 11 AC220-240/DC220V +SHT 11 DC48~60V +SHT 11 DC24V +SHT 11 AC380-415V D +SHT 11 AC220-240/DC220V D +SHT 11 AC/DC110V D		+SHT 12 AC380-415V +SHT 12 AC220-240/DC220V +SHT 12 AC/DC110V					
Closing release XF (remote ON)	separately	XF 11 AC380-415V XF 11 AC220-240/DC220V XF 11 AC/DC110V XF 11 DC48~60V XF 11 DC24V		XF 12 AC380-415V XF 12 AC220-240/DC220V XF 12 AC/DC110V					
	premounted	+XF 11 AC380-415V +XF 11 AC220-240/DC220V +XF 11 AC/DC110V +XF 11 DC48~60V +XF 11 DC24V		+XF 12 AC380-415V +XF 12 AC220-240/DC220V +XF 12 AC/DC110V					
Undervoltage release UVT (remote OFF inverse logic)	separately	UVT 11 AC380-415V UD UVT 11 AC220-240V UD UVT 11 DC48~60V UVT 11 DC24 UVTR 11 AC380-415V D1-5s UVTR 11 AC220-240V D1-5s		UVT 12 AC380-415V UD UVT 12 AC220-240V UD UVTR 12 AC380-415V D1-5s UVTR 12 AC220-240V D1-5s					
	premounted	+UVT 11 AC380-415V UD +UVT 11 AC220-240V UD +UVT 11 DC48~60V +UVT 11 DC24 +UVTR 11 AC380-415V D1-5s +UVTR 11 AC220-240V D1-5s		+UVT 12 AC380-415V UD +UVT 12 AC220-240V UD +UVTR 12 AC380-415V D1-5s +UVTR 12 AC220-240V D1-5s					
Motor drive MD (automatic spring charge)	separately	MD 11 AC380-415V MD 11 AC230/DC220 MD 11 AC/DC110V MD 11 DC48 MD 11 DC24		MD 12 AC380-415V MD 12 AC230/DC220V MD 12 DC110V		MD 13 AC380-415V MD 13 AC230/DC220V MD 13 AC/DC110V			
	premounted	+MD 11 AC380-415V +MD 11 AC230/DC220 +MD 11 AC/DC110V +MD 11 DC48 +MD 11 DC24		+MD 12 AC380-415V +MD 12 AC230/DC220V +MD 12 DC110V		+MD 13 AC380-415V +MD 13 AC230/DC220V +MD 13 AC/DC110V			
Key Lock Key KLIK (safety OFF lock key)	separately			N/A					
	premounted	+KLIK 11 1L1K +KLIK 11 2L1K +KLIK 11 3L2K		+KLIK 12 1L1K +KLIK 12 2L1K +KLIK 12 3L2K					

Ex9A and SU Accessories distribution

Distribution map of Ex9A accessories

Ex9A frame size		Ex9A16 (11)		Ex9A25 (12)		Ex9A32 (13)		Ex9A40 (14)	
Accessory		Fixed	Withdra- wable	Fixed	Withdra- wable	Fixed	Withdra- wable	Fixed	Withdra- wable
Mechanical interlock IPA	separately	IPA 11F 2-2	IPA 11D/O 2-2	IPA 12F 2-2 IPA 12F 3-2	IPA 12D/O 2-2 IPA 12D/O 3-2	IPA 12F 2-2 IPA 12F 3-2	IPA 12D/O 2-2 IPA 12D/O 3-2	IPA 12F 2-2 IPA 12F 3-2	IPA 12D/O 2-2 IPA 12D/O 3-2
	premounted	N/A							
Cassette position indicator EF	separately	N/A							
	premounted	N/A	+EF 11	N/A	+EF 12	N/A	+EF 12	N/A	+EF 12
Pushbutton lock (safety lock for ON and OFF buttons)	separately	N/A							
	premounted	+VBP 11		+VBP 12					
Connection terminals in vertical position	separately	N/A							
	premounted	+VCP							
Connection terminals with spreaders TEX	separately	TEX 11 3P 1000-1600A TEX 11 3P 400-800A TEX 11 4P 1000-1600A TEX 11 4P 400-800A		N/A					
	premounted	+TEX 11 3P 1000-1600A +TEX 11 3P 400-800A +TEX 11 4P 1000-1600A +TEX 11 4P 400-800A		N/A					
Spare rear connection terminals RCP (horizontal)	separately	RCP 11 3P 400-800A RCP 11 3P 1000-1600A RCP 11 4P 400-800A RCP 11 4P 1000-1600A		RCP 12 3P 630-1600A RCP 12 4P 630-1600A		RCP 13 3P 1600-2500A RCP 13 4P 1600-2500A RCP 13 3P 3200A RCP 13 4P 3200A		RCP 13 3P 1600-2500A RCP 13 4P 1600-2500A	
	premounted	N/A							
Spare rear connection terminals RCPV (Vertical)	separately	Same as RCP		Same as RCP		RCP 13 3P 1600-2500A RCP 13 4P 1600-2500A RCPV 13 3P 2900-3200A RCPV 13 4P 2900-3200A		RCPV-F 14 3P 3200A	RCPV-DO 14 3P 3200A
	premounted	N/A							
Phase barriers DPS / PHS	separately	PHS 11 3P PHS 11 4P	DPS 11 3P DPS 11 4P	PHS 12 3P PHS 12 4P	DPS 12 3P DPS 12 4P	PHS 13 3P PHS 13 4P	DPS 13 3P DPS 13 4P	PHS 13 3P PHS 13 4P	DPS 13 3P DPS 13 4P
	premounted	N/A							
Door frame DDP / CDP (spare)	separately	CDP 11	DDP 11	CDP 12	DDP 12	CDP 13	DDP 13	CDP 13	DDP 13
	premounted	N/A							

Ex9A and SU Accessories distribution

Distribution map of SU accessories

Smart unit type		SU3.0			SU4.0			SU5.0		
Accessory	type	A	P	H	A	P	H	A	P	H
+ZSI	premounted	-	-	■	-	-	■	-	-	■
Zone selective interlock, advanced selectivity feature										
+DO2	premounted	-	-	■	-	-	■	-	-	■
Programmable digital outputs compatible with ZSI option										
+DO4	premounted	-	-	■	-	-	■	-	-	■
Programmable digital outputs NOT compatible with ZSI option										
NEC	separately	■	■	■	■	■	■	■	■	■
External Neutral pole current transformer for 3P breakers										
+VM3P4W	premounted	-	■	■	-	■	■	-	■	■
3 phase 4 wire voltage measurement option										
+COM Modbus	premounted	-	-	■	-	-	■	-	-	■
Modbus RTU over RS485 software option										
LEC	separately	-	-	-	-	-	-	■	■	■
Earth leakage external differential current transformer.										

Available function: ■

Not available function: —

Ex9A and SU Accessories distribution

Internal accessories Ex9A air circuit breakers and switch disconnectors

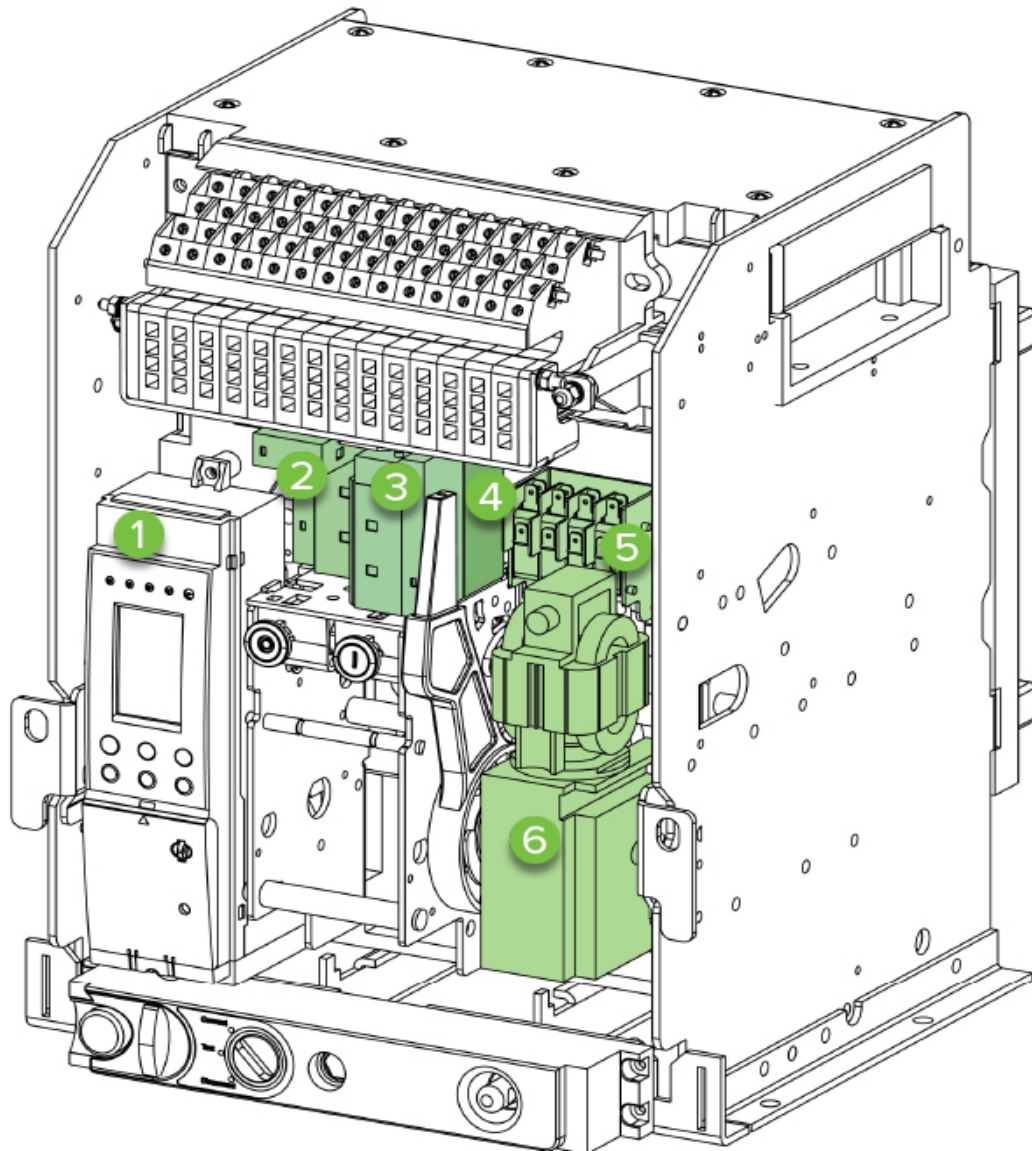

1

Signal contact
preassembled

2

Undervoltage
release
UVT1i

3

Closing release
XF1i

4

Shunt trip release
SHT1i

5

Auxiliary contacts
AX1i

6

Motor drive
MD1i

Signal contact preassembled on the SU only

Undervoltage releases UVT1i

Closing releases XF1i

Shunt trip releases SHT1i

Auxiliary contact AX1i

Motor drive MD1i

Please observe the accessory compatibility table located on the pages 2 and 3 to learn about the distribution of the accessories among the different frame sizes

Ex9A and SU Accessories distribution

External accessories Ex9A air circuit breakers and switch disconnectors



Position indicator
+EF1i



Phase barriers
PHS / DPS1i



Spare door frames
DDP / CDP1i



Horizontal spare
terminals
RCP1i

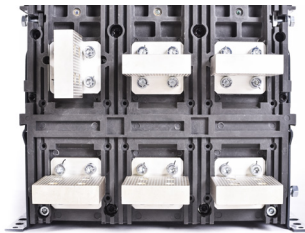

Vertical spare
terminals
RCPV1i



Connection terminals
with spreaders
TEX11



Mechanical interlock
IPA1i

Position indicators +EF1i

Phase barriers PHS / DPS1i

Spare door frames DDP / CDP1i

Horizontal spare terminals RCP1i

Vertical spare terminals RCPV1i

Connection terminals with spreaders TEX11

Mechanical interlock IPA1i

Functional accessories for **Ex9A** and **Ex9ASD**

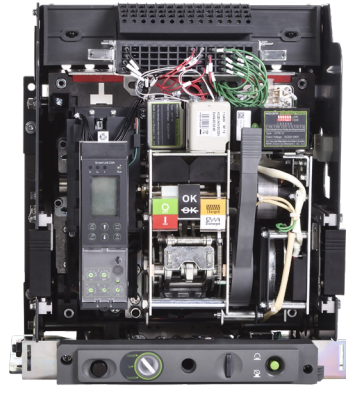
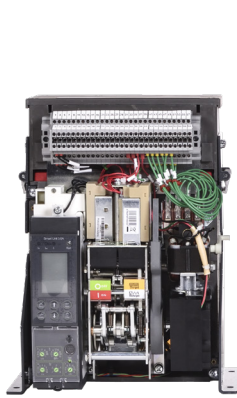

- Auxiliary contacts
- Signal contacts
- Shunt trip releases
- Undervoltage releases
- Closing releases
- Motor operators
- Position indicators
- ON / OFF buttonlock
- OFF position safety lock

The accessories listed in this section have the purpose of increase the protective and control functionalities of the basic setup of the air circuit breakers or the air switch disconnectors.

Mostly of these accessories can be ordered in both separately or premounted type. Only the accessories +EF, +VBP and +KLK must be ordered as a premounted accessory, since the implementation of such accessories requires mechanical adaptation of the circuit breakers to install them.

For further information please contact our technical department.

Certification marks



Functional accessories for **Ex9A** and **Ex9ASD**

Closing releases

- Remotely close (remote ON coil) the breaker after the spring has stored energy
- Versions for separately mounting as well as premounted



Version	For frame size	Operating voltage	Article No.	Type	Packing
Premounted	A16	380-415 V AC	112425	+XF 11 AC380-415V	1
Premounted	A16	220-240 V AC/DC	112424	+XF 11 AC220-240/DC220V	1
Premounted	A16	110 V AC/DC	112426	+XF 11 AC/DC110V	1
Premounted	A16	48-60 V DC	113788	+XF 11 DC48-60V	1
Premounted	A16	24 V DC	112427	+XF 11 DC24V	1
Premounted	A25/32/40	380-415 V AC	112433	+XF 12 AC380-415V	1
Premounted	A25/32/40	220-240 V AC/DC	112432	+XF 12 AC220-240/DC220V	1
Premounted	A25/32/40	110 V AC/DC	112434	+XF 12 AC/DC110V	1
Separately orderable	A16	380-415 V AC	112429	XF 11 AC380-415V	1
Separately orderable	A16	220-240 V AC/DC	112428	XF 11 AC220-240/DC220V	1
Separately orderable	A16	110 V AC/DC	112430	XF 11 AC/DC110V	1
Separately orderable	A16	48-60 V DC	113291	XF 11 DC48-60V	1
Separately orderable	A16	24 V DC	112431	XF 11 DC24V	1
Separately orderable	A25/32/40	380-415 V AC	112436	XF 12 AC380-415V	1
Separately orderable	A25/32/40	220-240 V AC/DC	112435	XF 12 AC220-240/DC220V	1
Separately orderable	A25/32/40	110 V AC/DC	112437	XF 12 AC/DC110V	1

Shunt trip releases

- Remotely opens (remote OFF coil) the breaker after supplying of control impulse
- Versions for separately mounting as well as premounted
- Separately orderable version can be used as first or second shunt trip release



Version	For frame size	Operating voltage	Article No.	Type	Packing
Premounted	A16	380-415 V AC	112405	+SHT 11 AC380-415V	1
Premounted	A16	220-240 V AC/DC	112404	+SHT 11 AC220-240/DC220V	1
Premounted	A16	110 V AC/DC	112406	+SHT 11 AC/DC110V	1
Premounted	A16	48-60 V DC	113789	+SHT 11 DC48-60V	1
Premounted	A16	24 V DC	112407	+SHT 11 DC24V	1
Premounted	A25/32/40	380-415 V AC	112419	+SHT 12 AC380-415V	1
Premounted	A25/32/40	220-240 V AC/DC	112418	+SHT 12 AC220-240/DC220V	1
Premounted	A25/32/40	110 V AC/DC	112420	+SHT 12 AC/DC110V	1
Separately orderable	A16	380-415 V AC	112412	SHT 11 AC380-415V	1
Separately orderable	A16	220-240 V AC/DC	112411	SHT 11 AC220-240/DC220V	1
Separately orderable	A16	110 V AC/DC	112413	SHT 11 AC/DC110V	1
Separately orderable	A16	48-60 V DC	113290	SHT 11 DC48-60V	1
Separately orderable	A16	24 V DC	112414	SHT 11 DC24V	1
Separately orderable	A25/32/40	380-415 V AC	112422	SHT 12 AC380-415V	1
Separately orderable	A25/32/40	220-240 V AC/DC	112421	SHT 12 AC220-240/DC220V	1
Separately orderable	A25/32/40	110 V AC/DC	112423	SHT 12 AC/DC110V	1

Second shunt trip releases

- Remotely opens (remote OFF coil) the breaker after supplying of control impulse
- Allows to have two independent shunt trip signals, with arbitrary combination of control voltages
- Second shunt release has the same functionality as the first one. It defines mounting position only.
- The second SHT replaces the UVT



Version	For frame size	Operating voltage	Article No.	Type	Packing
Premounted	A16	380-415 V AC	112409	+SHT 11 AC380-415V D	1
Premounted	A16	220-240 V AC/DC	112408	+SHT 11 AC220-240/DC220V D	1
Premounted	A16	110 V DC	112410	+SHT 11 AC/DC110V D	1
Separately orderable	A16	380-415 V AC	112416	SHT 11 AC380-415V D	1
Separately orderable	A16	220-240 V AC/DC	112415	SHT 11 AC220-240/DC220V D	1
Separately orderable	A16	110 V AC/DC	112417	SHT 11 AC/DC110V D	1

Functional accessories for **Ex9A** and **Ex9ASD**

Undervoltage releases

- Opens the breaker (remote OFF coil) when the voltage drops or power is off to prevent the load from damage caused by undervoltage
- Instantaneous and delayed types
- The delayed releases are used to eliminate circuit-breaker unwanted tripping during short time voltage drops
- Versions for separately mounting as well as premounted



Version	Delay	For frame size	Operating voltage	Article No.	Type	Packing
Premounted	undelayed	A16	380-415 V AC	112439	+UVT 11 AC380-415V UD	1
Premounted	undelayed	A16	220-240 V AC/DC	112438	+UVT 11 AC220-240V UD	1
Premounted	undelayed	A16	48-60 V DC	113787	+UVT 11 DC48-60 UD	1
Premounted	undelayed	A16	24 V DC	113783	+UVT 11 DC24 UD	1
Premounted	1-5s delay	A16	380-415 V AC	112441	+UVTR 11 AC380-415V D1-5s	1
Premounted	1-5s delay	A16	220-240 V AC/DC	112440	+UVTR 11 AC220-240V D1-5s	1
Premounted	undelayed	A25/32/40	380-415 V AC	112447	+UVT 12 AC380-415V UD	1
Premounted	undelayed	A25/32/40	220-240 V AC/DC	112446	+UVT 12 AC220-240V UD	1
Premounted	1-5s delay	A25/32/40	380-415 V AC	112449	+UVTR 12 AC380-415V D1-5s	1
Premounted	1-5s delay	A25/32/40	220-240 V AC/DC	112448	+UVTR 12 AC220-240V D1-5s	1
Separately orderable	undelayed	A16	380-415 V AC	112443	UVT 11 AC380-415V UD	1
Separately orderable	undelayed	A16	220-240 V AC/DC	112442	UVT 11 AC220-240V UD	1
Separately orderable	undelayed	A16	48-60 V DC	113292	UVT 11 DC48-60 UD	1
Separately orderable	undelayed	A16	24 V DC	113784	UVT 11 DC24 UD	1
Separately orderable	1-5s delay	A16	380-415 V AC	112445	UVTR 11 AC380-415V D1-5s	1
Separately orderable	1-5s delay	A16	220-240 V AC/DC	112444	UVTR 11 AC220-240V D1-5s	1
Separately orderable	undelayed	A25/32/40	380-415 V AC	112451	UVT 12 AC380-415V UD	1
Separately orderable	undelayed	A25/32/40	220-240 V AC/DC	112450	UVT 12 AC220-240V UD	1
Separately orderable	1-5s delay	A25/32/40	380-415 V AC	112453	UVTR 12 AC380-415V D1-5s	1
Separately orderable	1-5s delay	A25/32/40	220-240 V AC/DC	112452	UVTR 12 AC220-240V D1-5s	1

Auxiliary contacts

- Used for monitoring the ON/OFF status of circuit breaker
- Connection wires to auxiliary terminals in the scope of delivery
- Versions with 4 CO and 6 CO
- Versions for separately mounting as well as premounted
- Can be used also for time limiting of control signal for AX, XF and SHT



Version	For frame size	Contacts	Article No.	Type	Packing
Premounted	A16	4 CO	112396	+AX 11 44	1 set
Premounted	A16	6 CO	112397	+AX 11 66	1 set
Premounted	A25/32/40	4 CO	112400	+AX 12 44	1 set
Premounted	A25/32/40	6 CO	112401	+AX 12 66	1 set
Separately orderable	A16	4 CO	112398	AX 11 44	1 set
Separately orderable	A16	6 CO	112399	AX 11 66	1 set
Separately orderable	A25/32/40	4 CO	112402	AX 12 44	1 set
Separately orderable	A25/32/40	6 CO	112403	AX 12 66	1 set

Alarm contacts

- In the scope of delivery of a breaker, function of all type tripping unit SU
- 1 CO contact
- Connected to secondary terminals #3, 4, 5

Functional accessories for **Ex9A** and **Ex9ASD**

Motor operators

- The electric motor charges the spring mechanism automatically if necessary
- Versions for separately mounting as well as premounted
- Mechanical charging handle can be used when maintaining or without power supply
- Equipped with a limit switch contact which signals that spring is charged



Version	For frame size	Operating voltage	Article No.	Type	Packing
Premounted	A16	380-415 V AC	112455	+MD 11 AC380-415V	1
Premounted	A16	230 V AC/220 V DC	112454	+MD 11 AC230/DC220	1
Premounted	A16	110 V AC/DC	112456	+MD 11 AC/DC110V	1
Premounted	A16	48 V DC	113605	+MD 11 DC48V	1
Premounted	A16	24 V DC	113785	+MD 11 DC24V	1
Premounted	A25	380-415 V AC	112461	+MD 12 AC380-415V	1
Premounted	A25	230 V AC/220 V DC	112460	+MD 12 AC230/DC220V	1
Premounted	A25	110 V DC	112462	+MD 12 DC110V	1
Premounted	A32/40	380-415 V AC	112467	+MD 13 AC380-415V	1
Premounted	A32/40	230 V AC/220 V DC	112466	+MD 13 AC230/DC220V	1
Premounted	A32/40	110 V AC/DC	112468	+MD 13 AC/DC110V	1
Separately orderable	A16	380-415 V AC	112458	MD 11 AC380-415V	1
Separately orderable	A16	230 V AC/220 V DC	112457	MD 11 AC230/DC220	1
Separately orderable	A16	110 V AC/DC	112459	MD 11 AC/DC110V	1
Separately orderable	A16	48 V DC	113606	MD 11 DC48V	1
Separately orderable	A16	24 V DC	113786	MD 11 DC24V	1
Separately orderable	A25	380-415 V AC	112464	MD 12 AC380-415V	1
Separately orderable	A25	230 V AC/220 V DC	112463	MD 12 AC230/DC220V	1
Separately orderable	A25	110 V DC	112465	MD 12 DC110V	1
Separately orderable	A32/40	380-415 V AC	112470	MD 13 AC380-415V	1
Separately orderable	A32/40	230 V AC/220 V DC	112469	MD 13 AC230/DC220V	1
Separately orderable	A32/40	110 V AC/DC	112471	MD 13 AC/DC110V	1

Position indicators

- Indicate position of the breaker - connected, test, disconnected
- For withdrawable type devices only
- 3 CO contacts, one contact for each ACB position
- Connected to secondary terminals #58, 59, 60 (Connected), #61, 62, 63 (Test), #64, 65, 66 (Disconnected)
- Premounted version only - in the scope of delivery there are additional secondary terminals #58-66



Version	For frame size	Article No.	Type	Packing
Premounted	A16	112507	+EF 11	1
Premounted	A25/32/40	112508	+EF 12	1

Functional accessories for **Ex9A** and **Ex9ASD**

Pushbutton lock devices

- The cover prevents access to control push button of the breaker
- Premounted version only
- Scope of delivery: Lockable cover (lock with key is not a part of delivery)



Version	For frame size	Article No.	Type	Packing
Premounted	A16	112509	+VBP 11	1
Premounted	A25/32/40	112510	+VBP 12	1

OFF position keylocks

- Block a breaker in OFF position to ensure the breaker cannot be closed
- Premounted version only
- One circuit breaker is provided with one lock and one key
Two circuit breakers are provided with two locks and one key (necessary to mark in order)
Three circuit breakers are provided with three locks and two keys (necessary to mark in order)



Number of ACBs to share the same key	For frame size	Article No.	Type	Packing
1	A16	112472	+KLK 11 1L1K	1 set
2	A16	112473	+KLK 11 2L1K	1 set
3	A16	112474	+KLK 11 3L2K	1 set
1	A25/32/40	112475	+KLK 12 1L1K	1 set
2	A25/32/40	112476	+KLK 12 2L1K	1 set
3	A25/32/40	112477	+KLK 12 3L2K	1 set

Notes

A large grid of dashed lines for writing notes, consisting of 20 columns and 30 rows.

Installation accessories for **Ex9A** and **Ex9ASD**

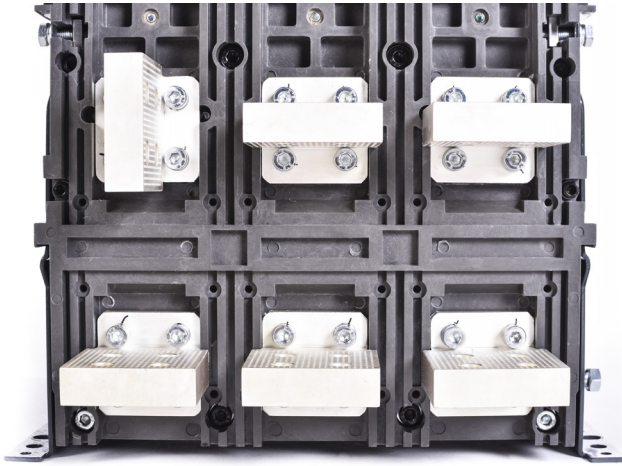

- Premounted terminals orientation
- Spare connection terminals (Horizontal)
- Spare connection terminals (Vertical)
- Connection terminals with spreaders
- Phase barriers
- Spare door frame
- Mechanical interlocks

The accessories listed in this section has the purpose of easing the installation process and improving the interconnectivity of the air circuit breaker or air switch disconnectors with the installation conductors.

It is important to notice that the terminals of the breakers with bigger nominal currents (2900 — 4000 A) are not symmetrical, and for these same circuit breakers the vertical and horizontal type of terminals are different.

For further information of the interconnection characteristics, type of terminals and other accessories please observe the air circuit breakers manual or communicate with our technical department for additional support.

Certification marks



Installation accessories for **Ex9A** and **Ex9ASD**

Main terminals distribution by frame size, current and type (Ex9A16 and Ex9A25)

Type	I_n	Fixed		Withdrawable	
		Horizontal (default)	Vertical (+VCP)	Horizontal (default)	Vertical (+VCP)
Ex9A16	1600 A				
Ex9A25	2000 A				
	2500 A				

- Fields with the same color indicates that the same type of terminal is used.
- Merged fields use the same type of terminals.
- The information of the table is valid for both 3P and 4P versions
- The default orientation of the terminals is horizontal position, please preorder the item +VCP together with the ACB to receive the vertical type of terminals instead.

Vertically premounted main terminals

- Defines vertical orientation of pre-mounted main terminals (as default in horizontal position)

For frame	Article No.	Type	Packing
A16/25/32/40	113796	+VCP	1

Installation accessories for **Ex9A** and **Ex9ASD**

Main terminals distribution by frame size, current and type (Ex9A32 and Ex9A40)

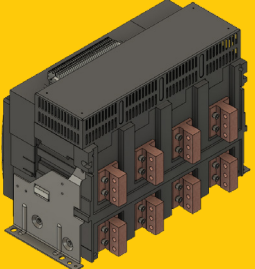
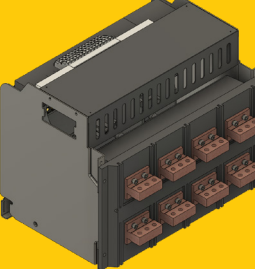
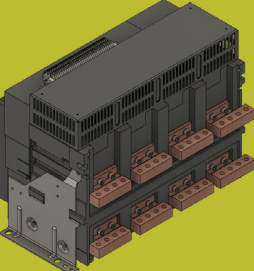
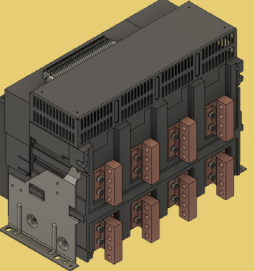
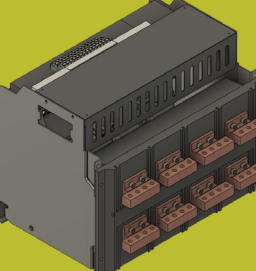
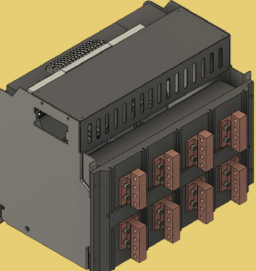
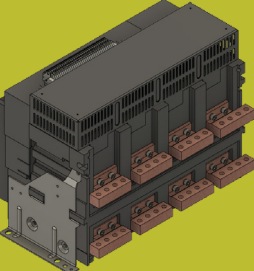
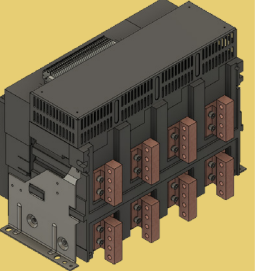
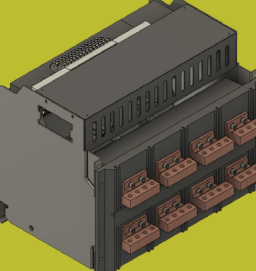
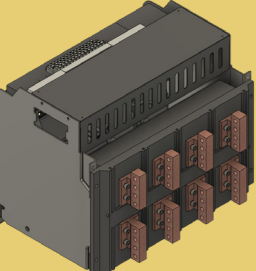
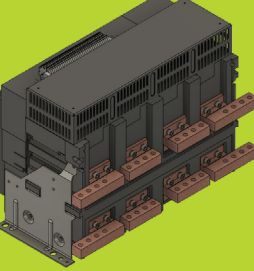
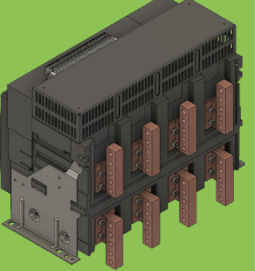
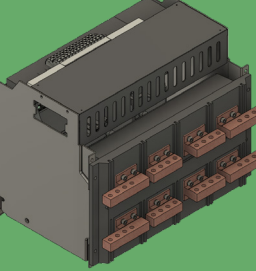
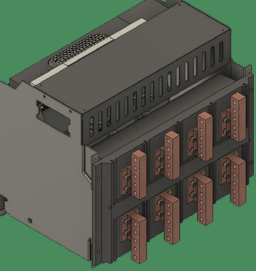
Type	I_n	Fixed		Withdrawable	
		Horizontal (default)	Vertical (+VCP)	Horizontal (default)	Vertical (+VCP)
Ex9A32	2500 A				
	3200 A				
Ex9A40	3200 A				
	4000 A				

- Fields with the same color indicates that the same type of terminal is used.
- Merged fields use the same type of terminals.
- The information of the table is valid for both 3P and 4P versions
- The default orientation of the terminals is horizontal position, please preorder the item +VCP together with the ACB to receive the vertical type of terminals instead.

Vertically pre-mounted main terminals

- Defines vertical orientation of pre-mounted main terminals (as default in horizontal position)

For frame	Article No.	Type	Packing
A16/25/32/40	113796	+VCP	1

Installation accessories for **Ex9A** and **Ex9ASD**

Ex9A16 - Spare connection terminals up to 1600 A

- Main terminals, same as the ones in the scope of delivery of ACB, spare set
- Terminals for each pole are the same
- Suitable for both horizontal and vertical connection
- Same terminals for fixed and for withdrawable types
- 70mm pitch from phase to phase
- 1 set includes 3 plates for 3P type of breakers and 4 terminal plates for 4P type of breakers

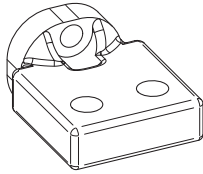
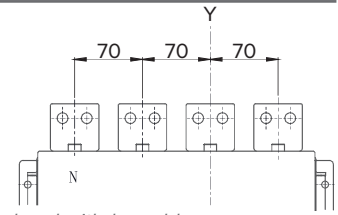

Rear connection plates - spare parts, horizontal and vertical connection, fixed and withdrawable

Orientation	For fr. size	Poles	Rated current	Article No.	Type	Packing
Horizontal / Vertical	A16	3P	400- 800 A	113797	RCP 11 3P 400-800A	1 set
Horizontal / Vertical	A16	3P	1000-1600 A	113798	RCP 11 3P 1000-1600A	1 set
Horizontal / Vertical	A16	4P	400- 800 A	113799	RCP 11 4P 400-800A	1 set
Horizontal / Vertical	A16	4P	1000-1600 A	113800	RCP 11 4P 1000-1600A	1 set

Ex9A25 - Spare connection terminals up to 1600 A

- Main terminals, same as the ones in the scope of delivery of ACB, spare set
- Terminals for each pole are the same
- Suitable for both horizontal and vertical connection
- Same terminals for fixed and for withdrawable types
- 95 mm pitch from phase to phase
- 1 set includes 3 plates for 3P type of breakers and 4 terminal plates for 4P type of breakers

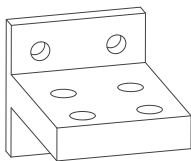
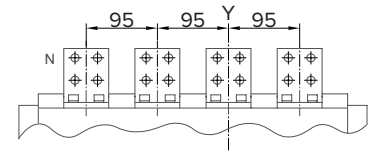

Rear connection plates - spare parts, horizontal and vertical connection, fixed and withdrawable

Orientation	For fr. size	Poles	Rated current	Article No.	Type	Packing
Horizontal / Vertical	A25	3P	630-1600 A	113801	RCP 12 3P 630-1600A	1 set
Horizontal / Vertical	A25	4P	630-1600 A	113802	RCP 12 4P 630-1600A	1 set

Installation accessories for **Ex9A** and **Ex9ASD**

Ex9A25 Fixed ACB Horizontal/Vertical - Spare connection terminals up to 2500 A

- Main terminals, same as the ones in the scope of delivery of ACB, spare set
- Terminals for each pole are the same
- Suitable for both horizontal and vertical connection
- Terminals for fixed type of ACB only
- 95 mm pitch from phase to phase
- 1 set includes 3 plates for 3P type of breakers and 4 terminal plates for 4P type of breakers

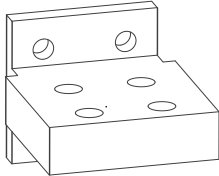
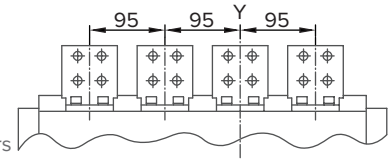

Rear connection plates - spare parts, horizontal and vertical connection, fixed

Orientation	For fr. size	Poles	Rated current	Article No.	Type	Packing
Horizontal / Vertical	A25	3P	2000-2500 A	113803	RCP-F 12 3P 2000-2500A	1 set
Horizontal / Vertical	A25	4P	2000-2500 A	113804	RCP-F 12 4P 2000-2500A	1 set

Ex9A25 Withdrawable ACB Horizontal/Vertical - Spare connection terminals up to 2500 A

- Main terminals, same as the ones in the scope of delivery of ACB, spare set
- Terminals for each pole are the same
- Suitable for both horizontal and vertical connection
- Terminals for withdrawable type of ACB only
- 95 mm pitch from phase to phase
- 1 set includes 3 plates for 3P type of breakers and 4 terminal plates for 4P type of breakers

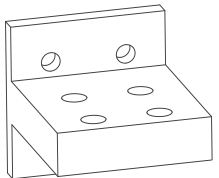
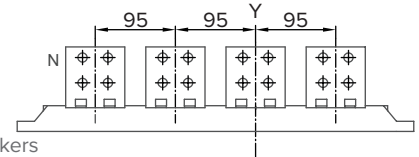

Rear connection plates - spare parts, horizontal and vertical connection, withdrawable

Orientation	For fr. size	Poles	Rated current	Article No.	Type	Packing
Horizontal / Vertical	A25	3P	2000-2500 A	113805	RCP-DO 12 3P 2000-2500A	1 set
Horizontal / Vertical	A25	4P	2000-2500 A	113806	RCP-DO 12 4P 2000-2500A	1 set

Ex9A32 / 40 Horizontal- Spare connection terminals up to 2500 A

- Main terminals, same as the ones in the scope of delivery of ACB, spare set
- Terminals for each pole are the same
- Suitable for both horizontal and vertical connection
- Same terminals for fixed and for withdrawable types
- 115 mm pitch from phase to phase
- 1 set includes 3 plates for 3P type of breakers and 4 terminal plates for 4P type of breakers

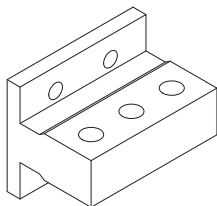
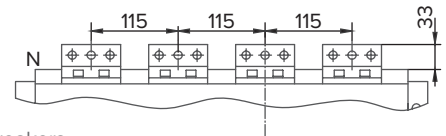

Rear connection plates - spare parts, horizontal and vertical connection, fixed and withdrawable

Orientation	For fr. size	Poles	Rated current	Article No.	Type	Packing
Horizontal / Vertical	A32/40	3P	1600-2500 A	113807	RCP 13 3P 1600-2500A	1 set
Horizontal / Vertical	A32/40	4P	1600-2500 A	113808	RCP 13 4P 1600-2500A	1 set

Installation accessories for **Ex9A** and **Ex9ASD**

Ex9A32 / 40 Horizontal - Spare connection terminals up to 3200 A

- Main terminals, same as the ones in the scope of delivery of ACB, spare set
- Terminals for each pole are not the same
- Suitable for horizontal connection only
- Same terminals for fixed and for withdrawable types
- 126 mm pitch from phase to phase
- 1 set includes 3 plates for 3P type of breakers and 4 terminal plates for 4P type of breakers

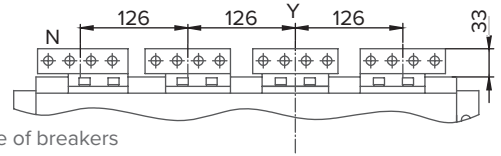

Rear connection plates - spare parts, horizontal connection, fixed and withdrawable

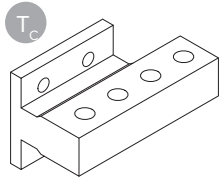
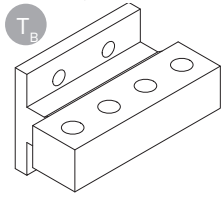
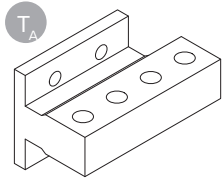

Orientation	For fr. size	Poles	Rated current	Article No.	Type	Packing
Horizontal	A32/40	3P	2900-3200 A	113809	RCP 13 3P 3200A	1 set
Horizontal	A32/40	4P	2900-3200 A	113810	RCP 13 4P 3200A	1 set

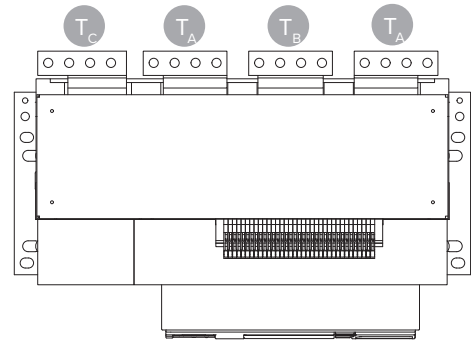
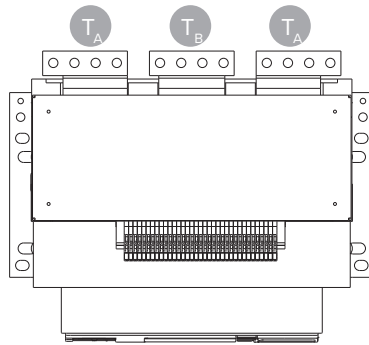

Installation accessories for **Ex9A** and **Ex9ASD**

Ex9A40 Fixed ACB Horizontal - Spare connection terminals up to 4000 A

- Main terminals, same as the ones in the scope of delivery of ACB, spare set
- Terminals for each pole are not the same
- Suitable for horizontal connection
- Same terminals for fixed type of ACB only
- 150 mm pitch from phase to phase
- 1 set includes 3 plates for 3P type of breakers and 4 terminal plates for 4P type of breakers

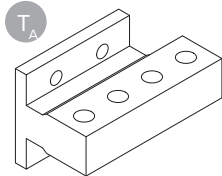
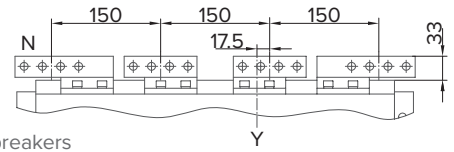

Rear connection plates - spare parts, horizontal and vertical connection, fixed

Orientation	For fr. size	Poles	Rated current	Article No.	Type	Packing
Horizontal	A40	3P	3200-4000 A	113811	RCP-F 14 3P 4000A	1 set
Horizontal	A40	4P	3200-4000 A	113812	RCP-F 14 4P 4000A	1 set

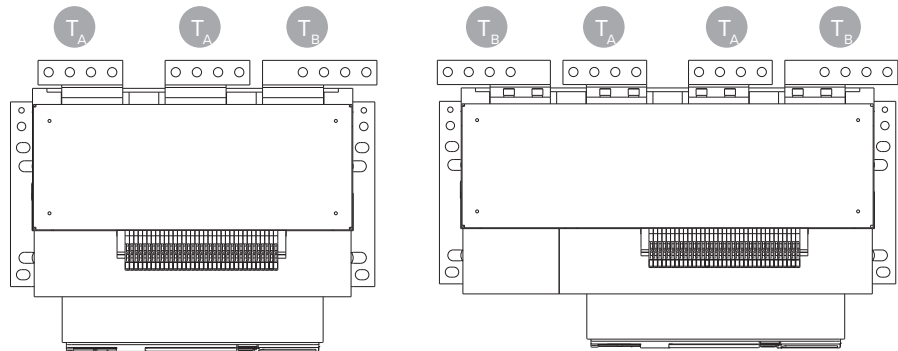
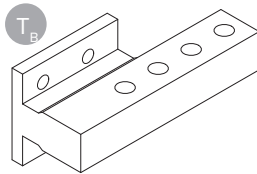

Ex9A40 Withdrawable Horizontal - Spare connection terminals up to 4000 A

- Main terminals, same as the ones in the scope of delivery of ACB, spare set
- Terminals for each pole are not the same
- Suitable for horizontal connection
- Same terminals for withdrawable type of ACB only
- 150 mm pitch from phase to phase
- 1 set includes 3 plates for 3P type of breakers and 4 terminal plates for 4P type of breakers

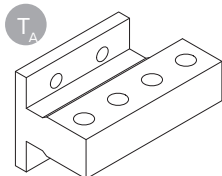
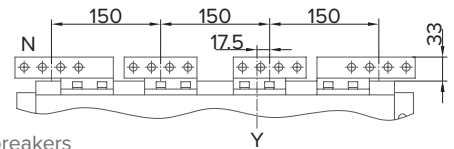

Rear connection plates - spare parts, horizontal and vertical connection, withdrawable

Orientation	For fr. size	Poles	Rated current	Article No.	Type	Packing
Horizontal	A40	3P	3200 A	113813	RCP-DO 14 3P 3200A	1 set
Horizontal	A40	4P	3200 A	113814	RCP-DO 14 4P 3200A	1 set
Horizontal	A40	3P	4000 A	113933	RCP-DO 14 3P 4000A	1 set
Horizontal	A40	4P	4000 A	113934	RCP-DO 14 4P 4000A	1 set

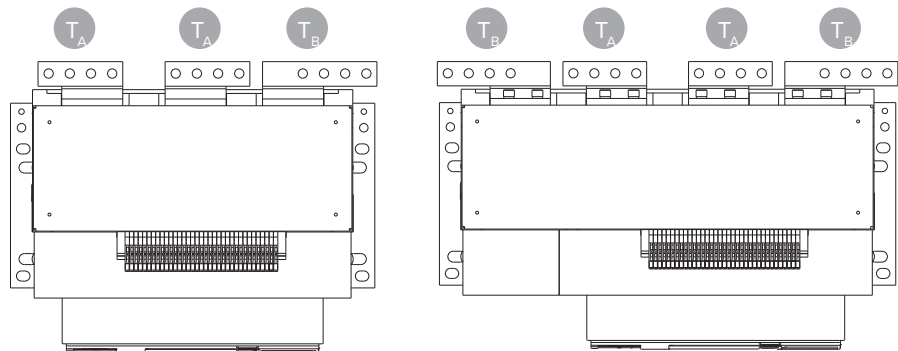
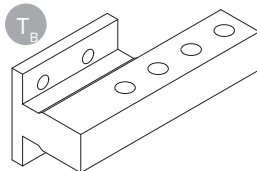

Installation accessories for Ex9A and Ex9ASD

Ex9A32 / 40 Vertical- Spare connection terminals up to 3200 A

- Main terminals, same as the ones in the scope of delivery of ACB, spare set
- Terminals for each pole are the same
- Suitable vertical connection only
- Same terminals for fixed and for withdrawable types
- 115 mm pitch from phase to phase
- 1 set includes 3 plates for 3P type of breakers and 4 terminal plates for 4P type of breakers

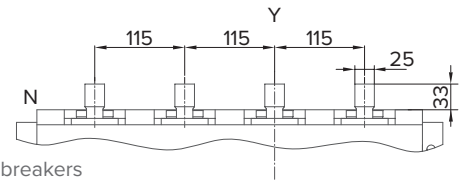

Rear connection plates - spare parts, horizontal and vertical connection, fixed and withdrawable

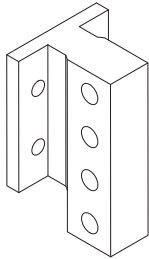

Orientation	For fr. size	Poles	Rated current	Article No.	Type	Packing
Vertical	A32/40	3P	3200 A	113815	RCPV 13 3P 2900-3200A	1 set
Vertical	A32/40	4P	3200 A	113816	RCPV 13 4P 2900-3200A	1 set

Ex9A40 Fixed ACB Vertical- Spare connection terminals up to 4000 A

- Main terminals, same as the ones in the scope of delivery of ACB, spare set
- Terminals for each pole are the same
- Suitable vertical connection only
- Same terminals for fixed and for withdrawable types
- 115 mm pitch from phase to phase
- 1 set includes 3 plates for 3P type of breakers and 4 terminal plates for 4P type of breakers

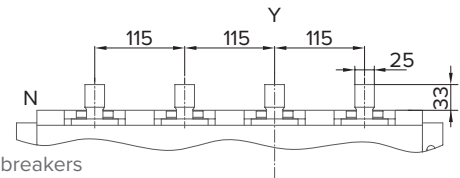

Rear connection plates - spare parts, horizontal and vertical connection, fixed

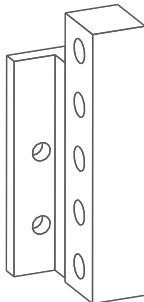

Orientation	For fr. size	Poles	Rated current	Article No.	Type	Packing
Vertical	A40	3P	4000 A	113817	RCPV-F 14 3P 3200A	1 set
Vertical	A40	4P	4000 A	113818	RCPV-F 14 4P 3200A	1 set
Vertical	A40	3P	4000 A	113835	RCPV-F 14 3P 4000A	1 set
Vertical	A40	4P	4000 A	113836	RCPV-F 14 4P 4000A	1 set

Ex9A40 Withdrawable ACB Vertical- Spare connection terminals up to 4000 A

- Main terminals, same as the ones in the scope of delivery of ACB, spare set
- Terminals for each pole are the same
- Suitable vertical connection only
- Same terminals for fixed and for withdrawable types
- 115 mm pitch from phase to phase
- 1 set includes 3 plates for 3P type of breakers and 4 terminal plates for 4P type of breakers

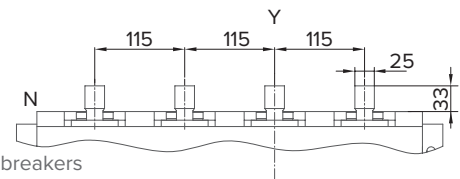

Rear connection plates - spare parts, horizontal and vertical connection, withdrawable

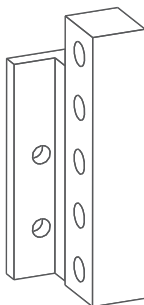

Orientation	For fr. size	Poles	Rated current	Article No.	Type	Packing
Vertical	A40	3P	4000 A	113819	RCPV-DO 14 3P 3200-4000A	1 set
Vertical	A40	4P	4000 A	113820	RCPV-DO 14 4P 3200-4000A	1 set
Vertical	A40	3P	4000 A	113837	RCPV-DO 14 3P 3200-4000A	1 set
Vertical	A40	4P	4000 A	113838	RCPV-DO 14 4P 3200-4000A	1 set

Installation accessories for Ex9A and Ex9ASD

Connection terminals

- Various possibilities of ACB connection
- Versions for separately mounting as well as premounted
- 1 set includes 6 plates for 3P type of breakers and 8 terminal plates for 4P type of breakers

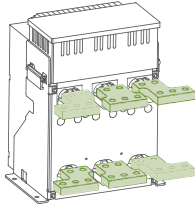

Connection terminals with spreaders

Version	For fr. size	Poles	Rated current	Article No.	Type	Packing
Premounted	A16	3P	400-630 A	112478	+TEX 11 3P 400-800A	1 set
Premounted	A16	3P	800-1600 A	112479	+TEX 11 3P 1000-1600A	1 set
Premounted	A16	4P	400-630 A	112480	+TEX 11 4P 400-800A	1 set
Premounted	A16	4P	800-1600 A	112481	+TEX 11 4P 1000-1600A	1 set
Separately orderable	A16	3P	400-630 A	112482	TEX 11 3P 400-800A	1 set
Separately orderable	A16	3P	800-1600 A	112483	TEX 11 3P 800-1600A	1 set
Separately orderable	A16	4P	400-630 A	112484	TEX 11 4P 400-800A	1 set
Separately orderable	A16	4P	800-1600 A	112485	TEX 11 4P 800-1600A	1 set

Phase barriers

- Improve insulation level between main terminals, not premounted accessory
- Versions for separately mounting for fixed and withdrawable devices
- Delivered as set (2pcs for 3P version, 3 pcs for 4P version)

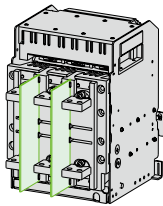

For fixed devices

Version	For frame size	Poles	Article No.	Type	Packing
Separately orderable	A16	3P	112494	PHS 11 3P	1 set
Separately orderable	A16	4P	112495	PHS 11 4P	1 set
Separately orderable	A25/32	3P	112496	PHS 12 3P	1 set
Separately orderable	A25/32	4P	112497	PHS 12 4P	1 set
Separately orderable	A40	3P	112498	PHS 13 3P	1 set
Separately orderable	A40	4P	112499	PHS 13 4P	1 set

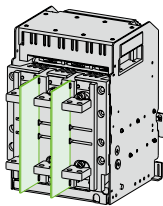

For withdrawable devices

Version	For frame size	Poles	Article No.	Type	Packing
Separately orderable	A16	3P	112488	DPS 11 3P	1 set
Separately orderable	A16	4P	112489	DPS 11 4P	1 set
Separately orderable	A25/32	3P	112490	DPS 12 3P	1 set
Separately orderable	A25/32	4P	112491	DPS 12 4P	1 set
Separately orderable	A40	3P	112492	DPS 13 3P	1 set
Separately orderable	A40	4P	112493	DPS 13 4P	1 set

Installation accessories for **Ex9A** and **Ex9ASD**

Doorframes (spare part)

- In the scope of delivery for each ACB
- Degree of protection IP40
- Can be ordered separately as a spare part



Version	For device version	For frame size	Article No.	Type	Packing
Separately orderable	Withdrawable	A16	113790	DDP 11	1
Separately orderable	Fixed	A16	113791	CDP 11	1
Separately orderable	Withdrawable	A25	113792	DDP 12	1
Separately orderable	Fixed	A25	113793	CDP 12	1
Separately orderable	Withdrawable	A32/40	113794	DDP 13	1
Separately orderable	Fixed	A32/40	113795	CDP 13	1

Mechanical Interlocks with cables

- For mutual interlocking of 2 or 3 ACB devices
- Mechanical interlock with cable
- Cable length for maximum distance of mounting positions of interlocks 2m
- Suitable for frame sizes A16, A25/A32/A40 (A16 cannot be combined with A25/A32/A40)
- Scope of delivery: 2 interlocks and 2 cables (2 ACBs version), 3 interlocks and 6 cables (3 ACBs version)
- Cable fixed in production
- Version for separately mounting only



For frame size	For No. of devices	Article No.	Type	Packing
A16, fixed	2	112500	IPA 11F 2-2	1 set
A16, withdrawable	2	112501	IPA 11D/O 2-2	1 set
A25/32/A40, fixed	2	112502	IPA 12F 2-2	1 set
A25/32/A40, withdrawable	2	112503	IPA 12D/O 2-2	1 set
A25/32/A40, fixed	3	112504	IPA 12F 3-2	1 set
A25/32/A40, withdrawable	3	112505	IPA 12D/O 3-2	1 set

Accessories of **SU** for **Ex9A**



- NEC Neutral conductor external current transformer
- WEC Ground conductor external current transformer
- LEC Leakage detection external differential transformer
- COM Modbus communication interface
- ZSI Zone selective interlock
- DO programmable digital outputs

The accessories listed on this section has the purpose of providing additional functions to the Smart Unit. These accessories will allow measurements and analysis outside of the circuit breaker, as well as improving selectivity characteristics or permitting remote monitoring and control via the Modbus communication interface.

For further information of the accessories that can be installed into the Smart Unit as well as its characteristics please observe the Smart Unit manuals and datasheets, or communicate with our technical department for additional support.

Certification marks



Accessories of **SU** for **Ex9A**

Current sensors for Neutral conductor NEC

- Current transformer for N-pole protection of 3P ACB in four-wire network
- To be mounted onto N conductor
- Connected to secondary terminals #28, 29
- Cannot be combined with WEC or LEC transformers for G and E functions, respectively

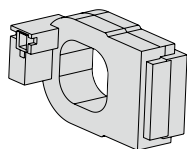

For frame size	Rated current	Article No.	Type	Packing
A16	800 A	113821	NEC 11 800A	1
A16	1600 A	113822	NEC 11 1600A	1
A25	800 A	118223	NEC 12 800A	1
A25	2500 A	118224	NEC 12 2500A	1
A32/40	4000 A	118225	NEC 14 4000A	1

ModBus communication function for tripping units (premounted)

- Additional communication possibility for tripping units
- Extension function always premounted for smart units of variants H (cannot be used for variant A nor P)
- ModBus-RTU communication protocol
- Connected via secondary terminals #10, 11, 12

Article No.	Type
112506	+COM MODBUS

ZSI (Zone Selective Interlock) function for tripping units (premounted)

- Allows Zone Selective Interlock, advanced feature for a fast disconnection of breakers in selective systems
- Two independent circuits (DI1/DO1, DI2/DO2)
- Extension function for smart units of variants H
- Possibility to select ZSI for protection functions S (ZSI IN ST) or S+G (ZSI). Selection can be done for both ZSI circuits independently.
- Connected via secondary terminals:
 - ZSI1 IN #20, 21
 - ZSI1 OUT #15, 19 (COM)
 - ZSI2 IN #22, 23
 - ZSI2 OUT #16, 19 (COM)
- When ZSI is activated, tripping delays are reduced to tripping time of instantaneous release. ZSI activation time is about 20 ms, typical total tripping time ca. 60 ms.

Accessories of **SU** for **Ex9A**

Programmable digital outputs DO (premounted)

- Optional functionality of tripping unit SU
- Orderable as premounted only
- Can be programmed as DO for alarm functions
- One different functionality can be selected for every DO. Activation of all DOs is synchronous, i.e. all DOs are activated with any selected function type
- Functionality can be selected in SU menu
- 4 digital outputs (when ZSI functionality is not used only) or 2 digital outputs (in combination with ZSI, identical common point)
- Available functions:

ACB trip indication in case of any fault (Fault trip)
ACB alarm indication (Alarm)
Indication of closed position (Closed)
Indication of open position (Open)
Self-diagnosis alarm (Diagnosis alarm)
Output for Load Monitor 1 (Load Monitor 1)
Output for Load Monitor 2 (Load Monitor 2)
Overload pre alarm (Overload pre alarm)
Trip due to overload - L function (Overload fault)
Trip due to short-circuitry - S function (Short time fault)
Trip due to short-circuitry - I function (Inst. fault)
Trip due to ground-fault - G function (Ground fault)
Ground-fault alarm - G function (Ground alarm)
Trip due to Earth-leakage - E function (Leakage fault)
Earth-leakage alarm - E function (Leakage alarm)

Current unbalance (I unbal fault)
Trip due to fault in Neutral conductor (Neutral fault)
Undervoltage (V under fault)
Overvoltage (V over fault)
Voltage unbalance (V unbal fault)
Underfrequency (F under fault)
Overfrequency (F over fault)
Reverse power (rP fault)
Phase rotation (Pr fault)
Temperature (T fault)
Current THD (I harmonic fault)
Voltage THD (V harmonic fault)
Ultrafast tripping of high-value short circuit currents (MCS/HSISC fault)

Wiring diagram

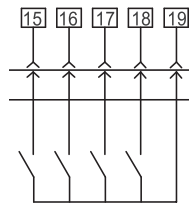

Closing releases XF

General parameters

Remotely connects the breaker after the electrical signal is provided. Requires to have the spring charged (MD)
 Operating voltage range 85 - 110% of nominal value U_e .

Electrical parameters

	XF 11	XF 12
Compatibility	Ex9A16	Ex9A25 / Ex9A32 / Ex9A40
Operating voltage U_e	380 — 415 V AC 220 — 240 V AC / 220 V DC 110 V AC / DC 48 — 60 V DC 24 V DC	380-415 V AC 220-240 V AC / 220 V DC 110 V AC / DC
Operating threshold (IEC/EN 60947-2)	85 — 110% U_e	
Minimum duration of control impuls	0.2 s	
Pick-up power time 100ms		
AC	200 VA	
DC	200 W	
Power consumption		
AC	5 VA	
DC	5 W	
Circuit breaker closing time	< 70 ms	
Breaking time	50 ± 10 ms	
Insulation voltage	2 kV	
Peak current	6 × I_n	
ACB secondary terminals	#33, 34	

Shunt trip releases SHT

General parameters

Remotely disconnects the breaker after the electrical signal is provided

Operating voltage range 85 - 110% of nominal value U_e .

Electrical parameters

	SHT 11	SHT 12
Compatibility	Ex9A16	Ex9A25 / Ex9A32 / Ex9A40
Operating voltage U_e	380 — 415 V AC 220 — 240 V AC / 220 V DC 110 V AC / DC 48 — 60 V DC 24 V DC	380-415 V AC 220-240 V AC / 220 V DC 110 V AC / DC
Operating threshold (IEC/EN 60947-2)	85 — 110% U_e	
Minimum duration of control impuls	0.2 s	
Pick-up power time 100ms		
AC	200 VA	
DC	200 W	
Power consumption		
AC	5 VA	
DC	5 W	
Circuit breaker closing time	< 70 ms	
Breaking time	50 ± 10 ms	
Insulation voltage	2 kV	
Peak current	6 × I_n	
ACB secondary terminals	#31, 32	

Undervoltage releases UVT

General parameters

Opens the breaker when the voltage drops or power off to prevent the load from damage caused by undervoltage
Remotely disconnects the breaker after the electrical signal is removed
The delayed types are used to eliminate circuit-breaker nuisance tripping during short voltage dips. The delay time is adjustable from 1 up to 5s
The undervoltage release instantaneously opens the circuit breaker when its supply voltage drops to a value between 35 % and 70 % of its rated voltage
If there voltage is less than 35 % of supply voltage U_e , it is impossible to close the circuit breaker
Circuit breaker can be closed when the supply voltage of the release is 85 % - 110 % of supply voltage U_e

Electrical parameters

	UVT 11	UVT 12
Compatibility	Ex9A16	Ex9A25 / Ex9A32 / Ex9A40
Operating voltage U_e	380 — 415 V AC 220 — 240 V AC / 220 V DC 48 — 60 V DC 24 V DC	380 — 415 V AC 220 — 240 V AC / 220 V DC
Operating threshold not close actuation closing		< 35 % U_e 35 — 70 % U_e 85 — 110 % U_e
Pick-up power time 100ms AC DC		200 VA 200 W
Power consumption AC DC		50VA 50 W
Accuracy		± 20 %
Insulation voltage		2 kV
ACB secondary terminals		#35, 36

Auxiliary contacts AX

General parameters

Monitors the ON/OFF status of circuit breaker
4 and 6 (CO) changeover contacts versions available
Can realise the control or interlock with other components, signal of indicator or relay
Connection wires to auxiliary terminals in the scope of delivery

Electrical parameters

	AX 11	AX 12
Compatibility	Ex9A16	Ex9A25 / Ex9A32 / Ex9A40
Operating voltage U_e	240 / 415 V AC 110 / 220 V DC	
Operating thermal current I_{th}	5 A	
Rated operating current I_e	2A / 415 V AC 2A / 230 V AC 0.25 A / 220 V DC 0.25 A / 110 V DC	2A / 415 V AC 2A / 230 V AC 0.3 A / 220 V DC 0.3 A / 110 V DC
Contacts	4 CO 6 CO	
Utilization category	AC-15 DC-13	
Related secondary terminals for withdrawable ACBs	AX1: NO #40, COM 41, NC 42 AX2: NO #43, COM 44, NC 45 AX3: NO #46, COM 47, NC 48 AX4: NO #49, COM 50, NC 51 AX5: NO #52, COM 53, NC 54 AX6: NO #55, COM 56, NC 13	
Related secondary terminals for fixed ACBs	AX1: NO #40, COM 41, NC 42 AX2: NO #43, COM 44, NC 45 AX3: NO #46, COM 47, NC 48 AX4: NO #49, COM 50, NC 51 AX5: NO #52, COM 53, NC 54 AX6: NO #55, COM 56, NC 13	

Connection diagram

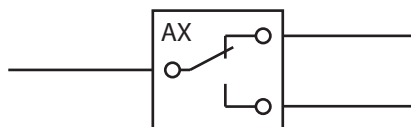

Motor operator MD

General parameters

The electric motor charges the spring mechanism which stores the energy to open and close the ACB properly
The electric motor MD is equipped with a limit switch which signals the "charged" position of the mechanism (spring is charged)
The spring-mechanism charging handle can be used when maintaining or without power supply

Electrical parameters

	MD 11	MD 12	MD13
Compatibility	Ex9A16	Ex9A25	Ex9A32 / Ex9A40
Operating voltage U_e	380 — 415 V AC 220 — 240 V AC / 220 V DC 110 V AC / DC 48 V DC 24 V DC	380 — 415 V AC 220 — 240 V AC / 220 V DC 110 V AC / DC	
Operating frequency	1 operating cycle in 3 minutes		
Operating threshold (IEC/EN 60947-2)	85 — 110% U_e		
Pick-up power time 100 ms			
AC	400 VA	400 VA	
DC	200 W	350 W	
Power consumption			
AC	75 VA	150 VA (A25 — A40 frame size)	
DC	75 W	150 W (A25 — A40 frame size)	
Charging time	3 — 4 s		
Insulation voltage	2 kV		
Peak current	$6 \times I_n$		
ACB secondary terminals	#37, 38, 39		

Pushbutton lock device VBP

General parameters

The cover prevents access to control push button of the breaker

Premounted only

Scope of delivery: Lockable cover (lock with key is not a part of delivery)

Mounting position

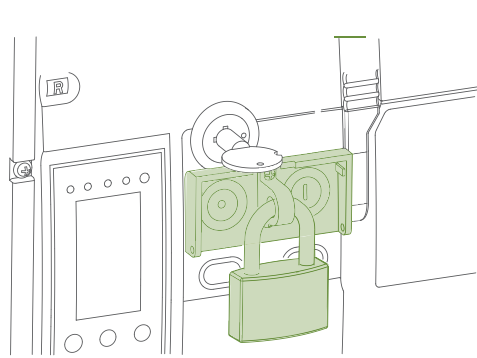

OFF position keylocks KLK

General parameters

Block a breaker in OFF position to ensure the breakers cannot be closed

One circuit breaker is provided with one lock and one key

Two circuit breakers are provided with two locks and one key

Three circuit breakers are provided with three locks and two keys

Mounting position

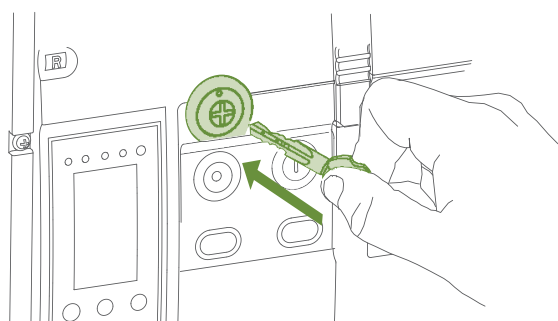

Tech. Data Installation Accessories **RCP/V A16**

Spare connection terminals for Ex9A16 up to 1600 A

General parameters

Terminal for each pole is the same
The same terminal is suitable for both horizontal and vertical position
The same terminal is suitable for both fixed and withdrawable types
70mm pitch from phase to phase in both horizontal and vertical position
Scope of delivery: 3 connection plates (Type A) for 3P breakers, 4 connection plates (Type A) for 4P breakers

Mechanical parameters

Type of plate	Terminal N (4P only)	Terminal 1-2 (phase A)	Terminal 3-4 (phase B)	Terminal 5-6 (phase C)
Horizontal Fixed	Terminal type A (T _A)			
Horizontal Withdrawable				
Vertical Fixed				
Vertical Withdrawable				
Terminal plate thickness				
400 – 630 A	10mm			
800 – 1600 A	16mm			
Connection screws	2 × M10			
Tightening torque	36 – 52Nm			
Busbar width	50mm			
Main terminals surface coating	silver			

Dimensions and drawing

Terminal type

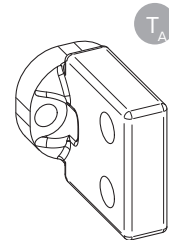
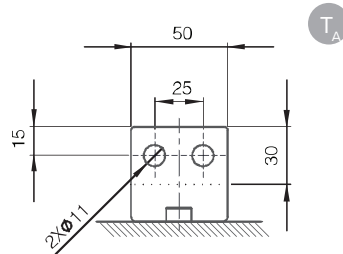
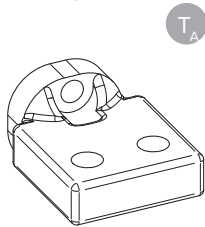

Fixed

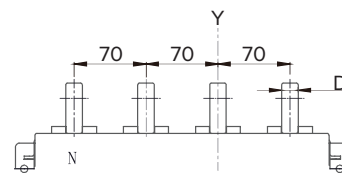
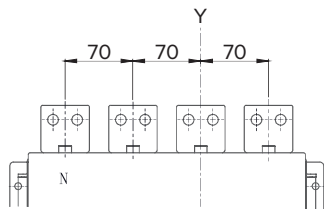

Withdrawable

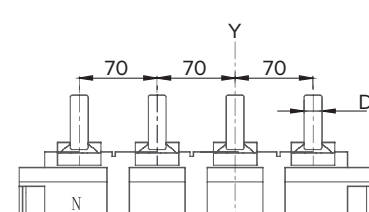
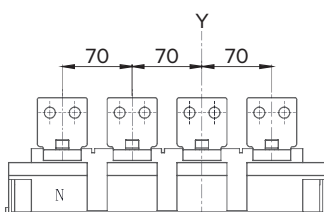

Tech. Data Installation Accessories **RCP/V A25**

Spare connection terminals for Ex9A25 up to 1600 A

General parameters

Terminal for each pole is the same
The same terminal is suitable for both horizontal and vertical position
The same terminal is suitable for both fixed and withdrawable types
95mm pitch from phase to phase in both horizontal and vertical position
Scope of delivery: 3 connection plates (Type A) for 3P breakers, 4 connection plates (Type A) for 4P breakers

Mechanical parameters

Type of plate	Terminal N (4P only)	Terminal 1-2 (phase A)	Terminal 3-4 (phase B)	Terminal 5-6 (phase C)
Horizontal Fixed	Terminal type A (T _A)			
Horizontal Withdrawable				
Vertical Fixed				
Vertical Withdrawable				
Terminal plate thickness				
630 – 1600 A	15mm			
2000 – 2500 A	20mm			
Connection screws	4 × M10			
Tightening torque	36 – 52Nm			
Busbar width	60mm			
Main terminals surface coating	silver			

Dimensions and drawings for terminals up to 1600 A

Terminal type

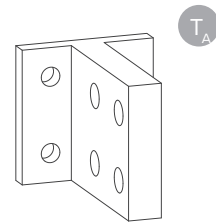
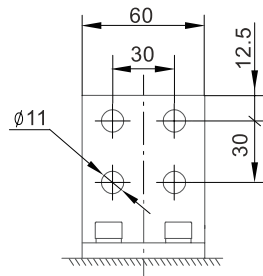
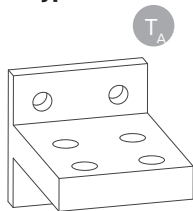

Fixed

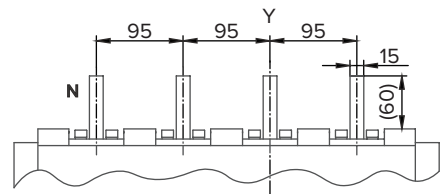
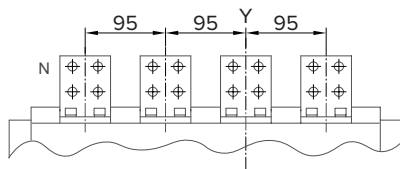

Withdrawable

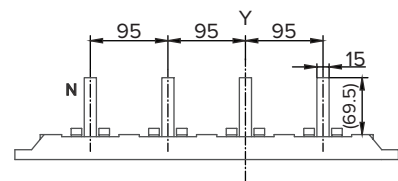
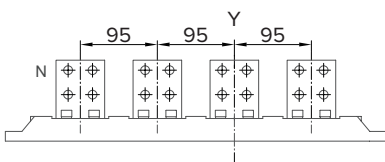

Tech. Data Installation Accessories **RCP/V A25**

Spare connection terminals for Ex9A25 up to 2500 A

General parameters

Terminal for each pole is the same
The same terminal is suitable for both horizontal and vertical position
Terminals for fixed type of Ex9A25 are different than the terminals for withdrawable type of Ex9A25 breaker
95mm pitch from phase to phase in both horizontal and vertical position
Scope of delivery: 3 connection plates (Type A/B) for 3P breakers, 4 connection plates (Type A/B) for 4P breakers

Mechanical parameters

Type of plate	Terminal N (4P only)	Terminal 1-2 (phase A)	Terminal 3-4 (phase B)	Terminal 5-6 (phase C)
Horizontal Fixed		Terminal type A (T _A)		
Horizontal Withdrawable		Terminal type B (T _B)		
Vertical Fixed		Terminal type A (T _A)		
Vertical Withdrawable		Terminal type B (T _B)		
Terminal plate thickness				
630 – 1600 A		15mm		
2000 – 2500 A		20mm		
Connection screws		4 × M10		
Tightening torque		36 – 52Nm		
Busbar width		70mm		
Main terminals surface coating		silver		

Dimensions and drawings for terminals up to 2500 A

Terminal type

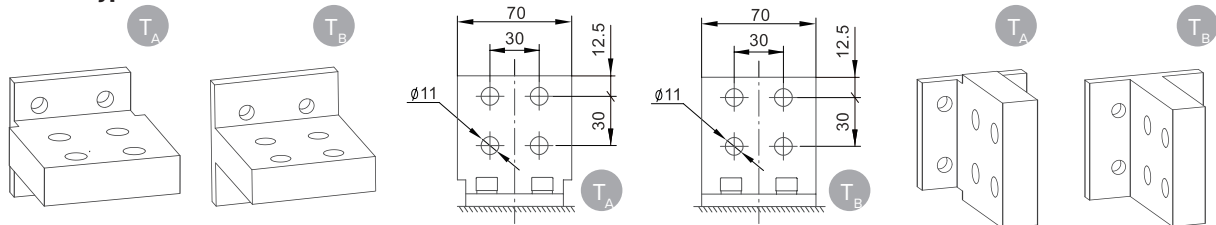

Fixed



Withdrawable



Spare connection terminals for Ex9A32 up to 2500 A

General parameters

Terminal for each pole is the same
The same terminal is suitable for both horizontal and vertical position
The same terminal is suitable for both fixed and withdrawable types
115mm pitch from phase to phase in both horizontal and vertical position
Scope of delivery: 3 connection plates (Type A) for 3P breakers, 4 connection plates (Type A) for 4P breakers

Mechanical parameters

Type of plate	Terminal N (4P only)	Terminal 1-2 (phase A)	Terminal 3-4 (phase B)	Terminal 5-6 (phase C)
Horizontal Fixed	Terminal type A (T _A)			
Horizontal Withdrawable				
Vertical Fixed				
Vertical Withdrawable				
Terminal plate thickness				
1600 – 2500 A	25mm			
2900 – 3200 A	25mm			
Connection screws	3 × M10			
Tightening torque	36 – 52Nm			
Busbar width	78mm			
Main terminals surface coating	silver			

Dimensions and drawings for terminals up to 2500 A

Terminal type

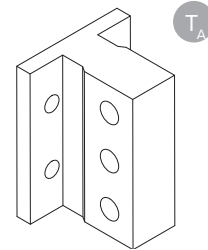
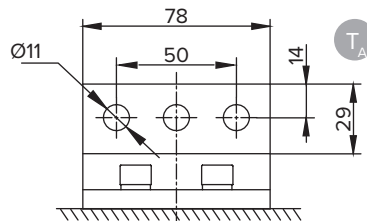
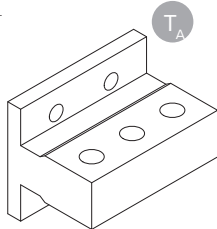

Fixed

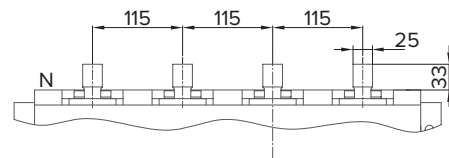
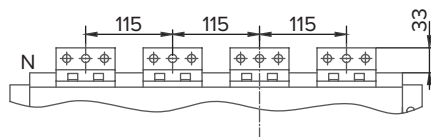

Withdrawable

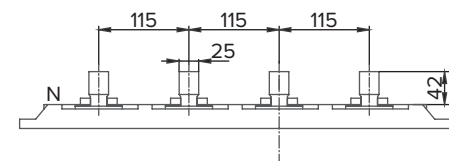
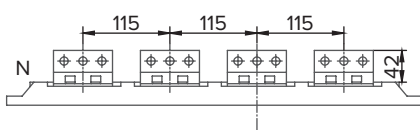

Spare connection terminals for Ex9A32 up to 3200 A

General parameters

Different shape of terminals for each pole
The distribution of terminals for horizontal and vertical positions are different
The same terminal is suitable for both fixed and withdrawable types
126 mm pitch from phase to phase with terminals in horizontal position, 115mm pitch from phase to phase with terminals in vertical position
Horizontal terminals, scope of delivery: 3 connection plates ($2 \times T_A, 1 \times T_B$) for 3P breakers, 4 connection plates ($2 \times T_A, 1 \times T_B, 1 \times T_C$) for 4P breakers
Vertical terminals, scope of delivery: 3 connection plates ($3 \times T_A$) for 3P breakers, 4 connection plates ($4 \times T_A$) for 4P breakers

Mechanical parameters

Type of plate	Terminal N (4P only)	Terminal 1-2 (phase A)	Terminal 3-4 (phase B)	Terminal 5-6 (phase C)
Horizontal Fixed	Terminal type C (T_C)	Terminal type A (T_A)	Terminal type B (T_B)	Terminal type A (T_A)
Horizontal Withdrawable				
Vertical Fixed	Terminal type A (T_A)			
Vertical Withdrawable				
Terminal plate thickness				
2000 – 2500 A	25mm			
2900 – 3200 A	25mm			
Connection screws	4 × M10			
Tightening torque	36 – 52Nm			
Busbar width	100mm			
Main terminals surface coating	silver			

Dimensions of terminals up to 3200 A

Terminal type

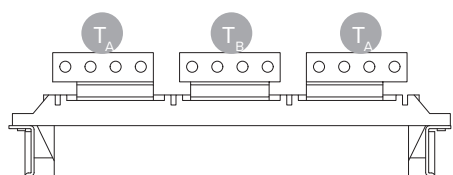
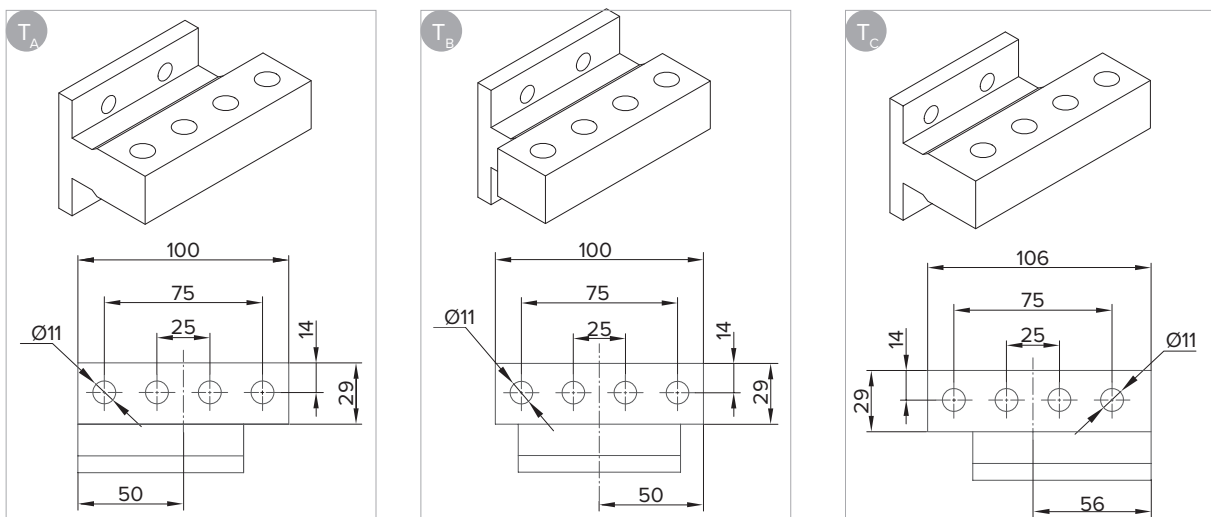

Fixed / Withdrawable 3P power connector distribution

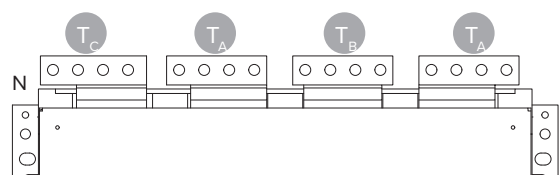

Fixed / Withdrawable 4P power connector distribution

Spare connection terminals for Ex9A32 up to 3200 A

Drawings for terminals up to 3200 A

Fixed

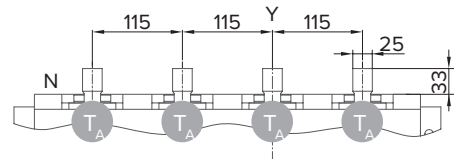
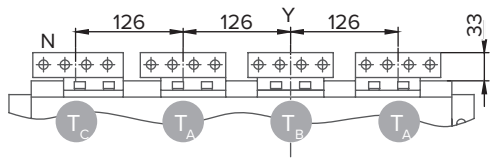

Withdrawable

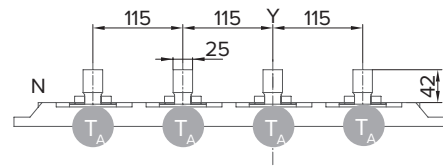
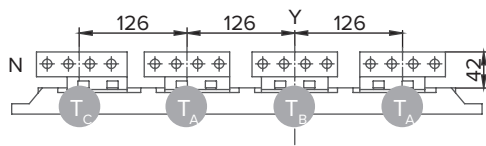

Spare connection terminals for Ex9A40 up to 3200 A

General parameters

Different shape of terminals for each pole
The distribution of terminals for horizontal and vertical positions are different
The same terminal is suitable for both fixed and withdrawable types
126 mm pitch from phase to phase with terminals in horizontal position, 115mm pitch from phase to phase with terminals in vertical position
Horizontal terminals, scope of delivery: 3 connection plates ($2 \times T_A, 1 \times T_B$) for 3P breakers, 4 connection plates ($2 \times T_A, 1 \times T_B, 1 \times T_C$) for 4P breakers
Vertical terminals, scope of delivery: 3 connection plates ($3 \times T_A$) for 3P breakers, 4 connection plates ($4 \times T_A$) for 4P breakers

Mechanical parameters

Type of plate	Terminal N (4P only)	Terminal 1-2 (phase A)	Terminal 3-4 (phase B)	Terminal 5-6 (phase C)
Horizontal Fixed	Terminal type C (T_C)	Terminal type A (T_A)	Terminal type B (T_B)	Terminal type A (T_A)
Horizontal Withdrawable				
Vertical Fixed	Terminal type A (T_A)			
Vertical Withdrawable				
Terminal plate thickness				
2000 – 2500 A	25mm			
2900 – 3200 A	25mm			
Connection screws	4 × M10			
Tightening torque	36 – 52Nm			
Busbar width	100mm			
Main terminals surface coating	silver			

Dimensions of terminals up to 3200 A

Terminal type

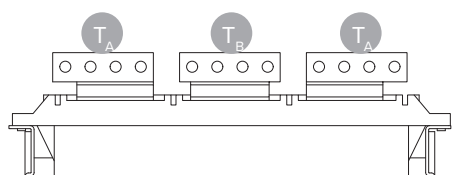
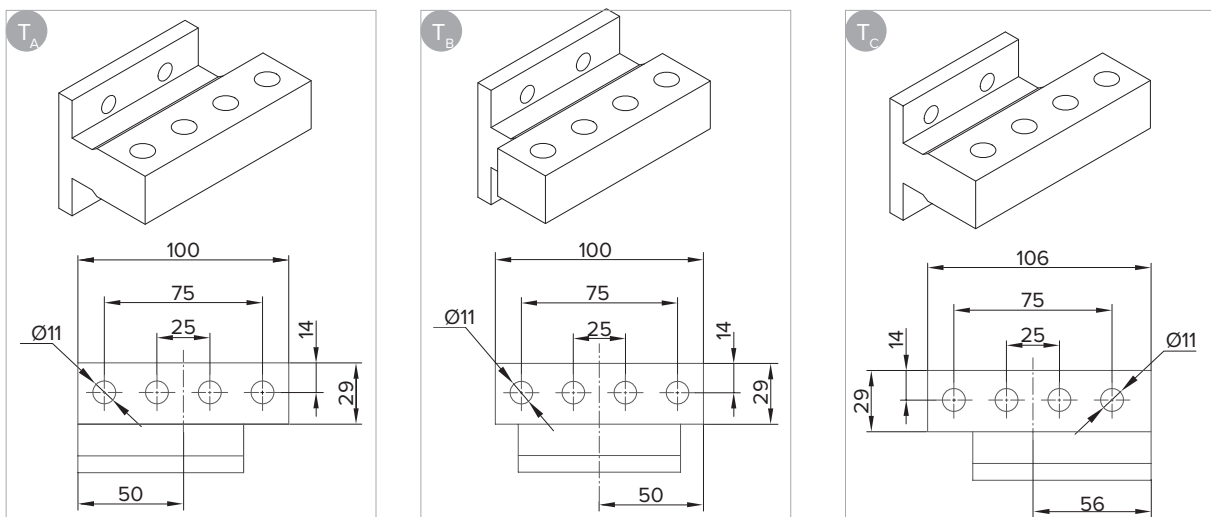

Fixed / Withdrawable 3P power connector distribution

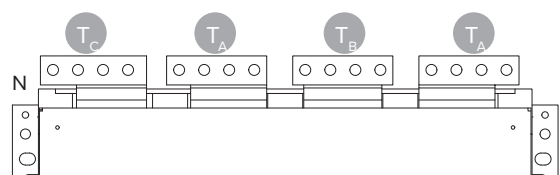

Fixed / Withdrawable 4P power connector distribution

Spare connection terminals for Ex9A40 up to 3200 A

Drawings for terminals up to 3200 A

Fixed

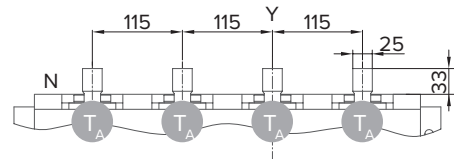
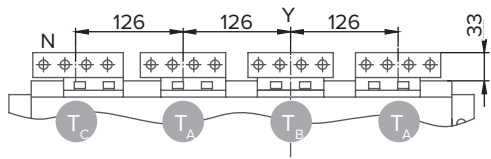

Withdrawable

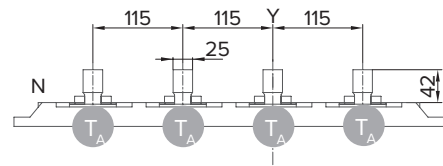
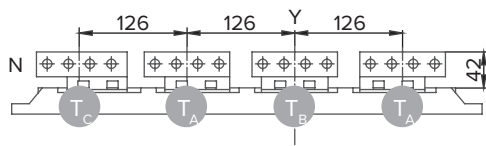

Spare connection terminals for Ex9A40 up to 4000 A

General parameters

Different shape of terminals for each pole
The distribution of terminals for horizontal and vertical positions are different
The same terminal is suitable for both fixed and withdrawable types
150 mm pitch from phase to phase with terminals in horizontal position, 115mm pitch from phase to phase with terminals in vertical position
Horizontal terminals, scope of delivery: 3 connection plates ($2 \times T_A / T_C, 1 \times T_B / T_D$) for 3P breakers, 4 connection plates ($2 \times T_A / T_C, 2 \times T_B / T_D$) for 4P breakers
Vertical terminals, scope of delivery: 3 connection plates ($3 \times T_E / T_F$) for 3P breakers, 4 connection plates ($4 \times T_E / T_F$) for 4P breakers

Mechanical parameters

Type of plate	Terminal N (4P only)	Terminal 1-2 (phase A)	Terminal 3-4 (phase B)	Terminal 5-6 (phase C)
Horizontal Fixed	Terminal type B (T_B)	Terminal type A (T_A)	Terminal type A (T_A)	Terminal type B (T_B)
Horizontal Withdrawable	Terminal type D (T_D)	Terminal type C (T_C)	Terminal type C (T_C)	Terminal type D (T_D)
Vertical Fixed	Terminal type E (T_E)			
Vertical Withdrawable	Terminal type F (T_F)			
Terminal plate thickness				
2900 – 3200 A	25mm			
4000 A				
Connection screws (horizontal)	4 × M10			
Connection screws (vertical)	5 × M10			
Tightening torque	36 – 52Nm			
Busbar width (horizontal)	100mm			
Busbar width (vertical)	125mm			
Main terminals surface coating	silver			

Installation drawings for terminals up to 4000 A

Fixed

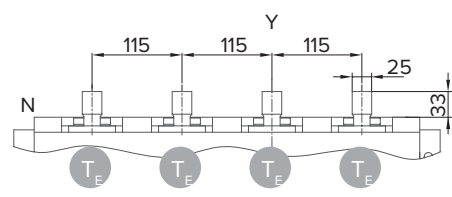
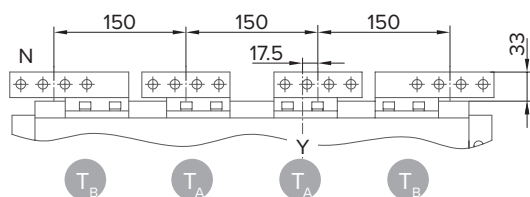

Withdrawable

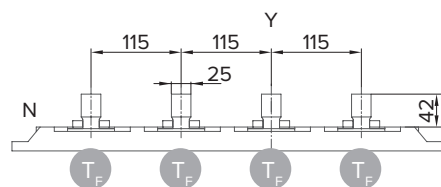
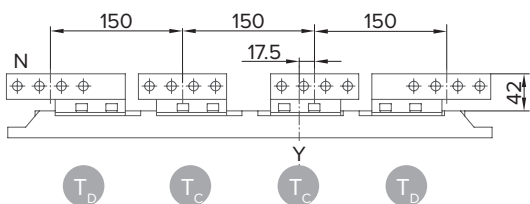

Spare connection terminals for Ex9A40 up to 4000 A

Dimensions of horizontal terminals up to 4000 A

Horizontal terminal types

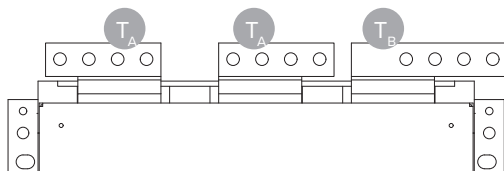
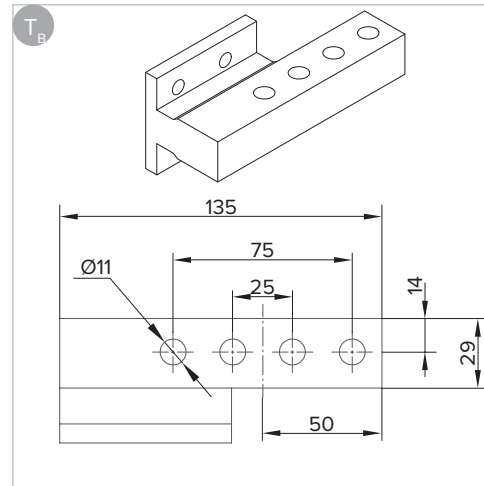
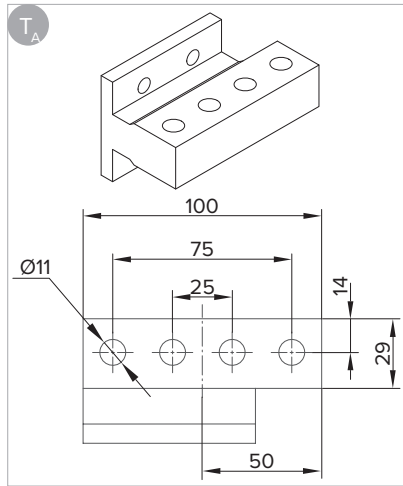

Fixed 3P power connector distribution

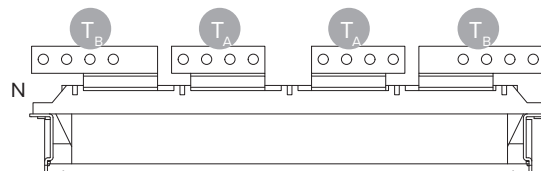

Fixed 4P power connector distribution

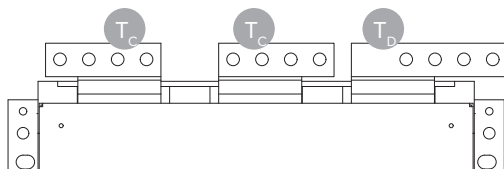
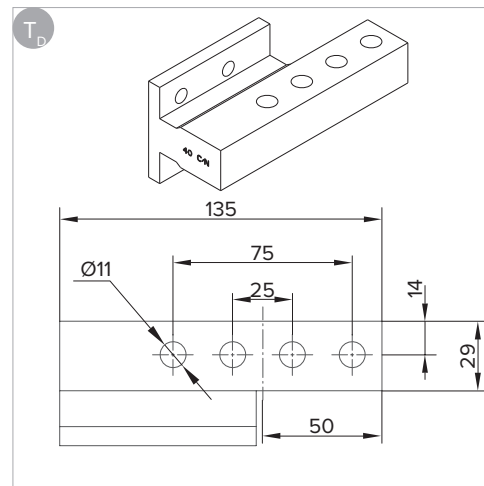
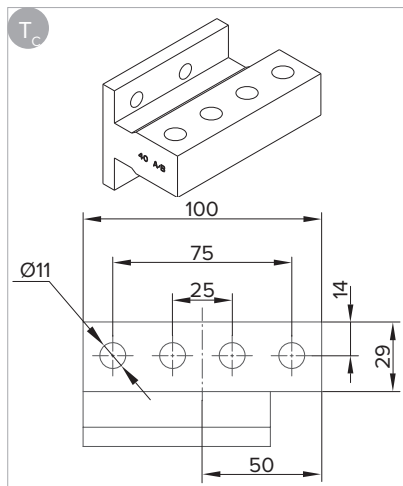

Withdrawable 3P power connector distribution

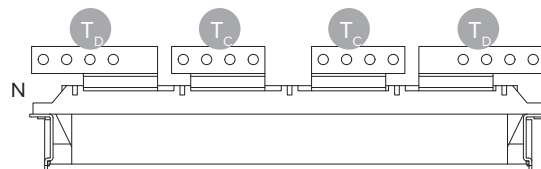

Withdrawable 4P power connector distribution

Spare connection terminals for Ex9A40 up to 4000 A

Dimensions of vertical terminals up to 4000 A

Vertical terminal types

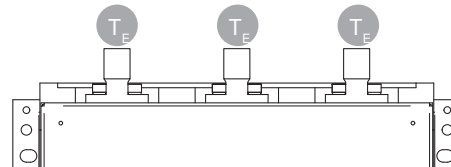
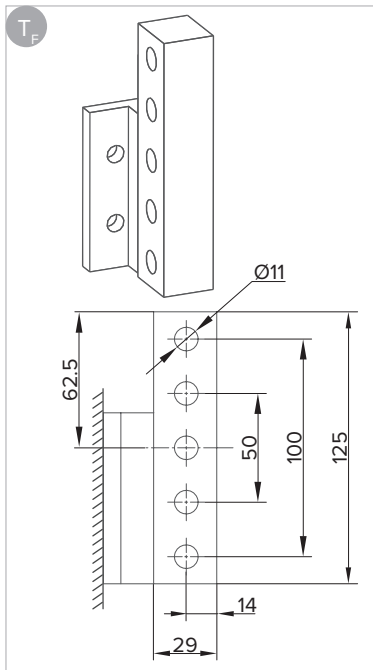

Fixed 3P power connector distribution

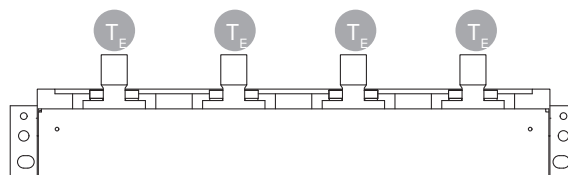

Fixed 4P power connector distribution

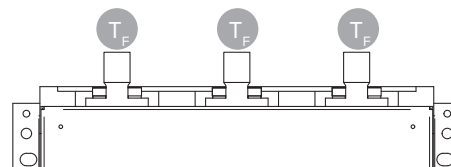
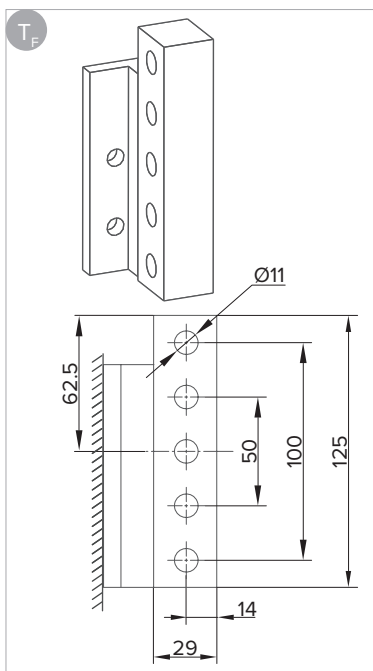

Withdrawable 3P power connector distribution

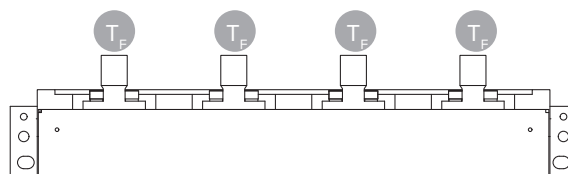

Withdrawable 4P power connector distribution

Connection terminals with spreaders for Ex9A16

General parameters

Different shape of terminals for each pole
For horizontal connection only
The same spreaders are suitable for both fixed and withdrawable types
95mm pitch from phase to phase with terminals in horizontal position, 115mm pitch from phase to phase with terminals in vertical position
Scope of delivery: 3 connection plates ($2 \times T_A, 1 \times T_B$) for 3P breakers, 4 connection plates ($2 \times T_C, 2 \times T_D$) for 4P breakers

Mechanical parameters

Type of plate	Terminal N (4P only)	Terminal 1-2 (phase A)	Terminal 3-4 (phase B)	Terminal 5-6 (phase C)
3P circuit breaker	-	Terminal type A (T_A)	Terminal type B (T_B)	Terminal type A (T_A)
4P circuit breaker	Terminal type C (T_C)	Terminal type D (T_D)	Terminal type D (T_D)	Terminal type C (T_C)
Terminal plate thickness				
400 – 630 A			10 mm	
800 – 1600 A			16 mm	
Connection screws			3 × M10	
Tightening torque			36 – 52 Nm	
Busbar width			77 mm	
Main terminals surface coating			silver	

Dimensions of 3P TEX terminals with spreaders for Ex9A16

3P TEX types

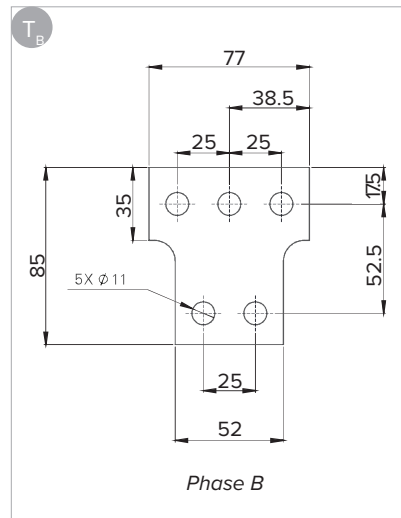
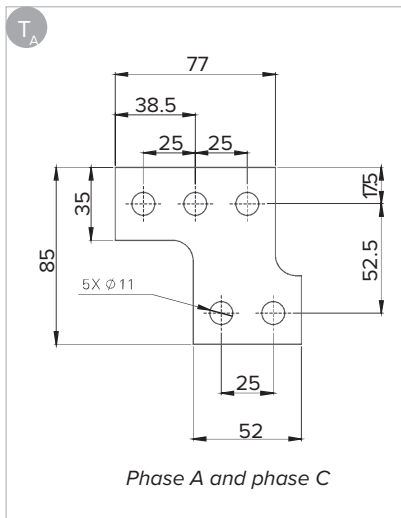

Connection terminals with spreaders for Ex9A16

Dimensions of 4P TEX terminals with spreaders for Ex9A16

4P TEX types

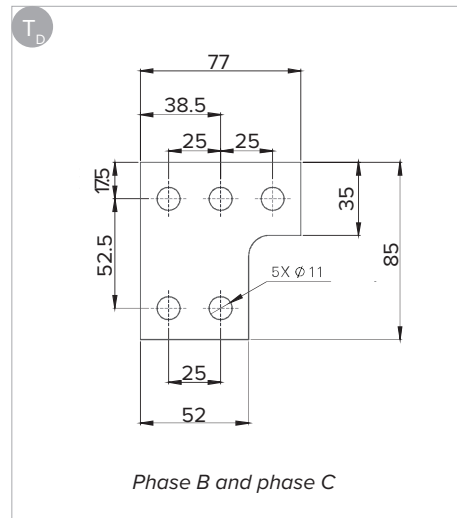
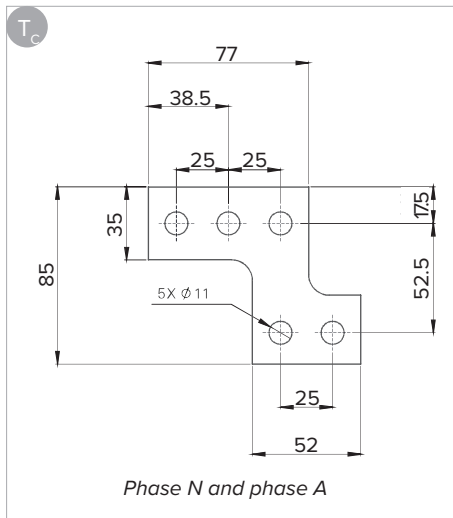

Installation drawings TEX terminals with spreaders for Ex9A16

3P TEX types

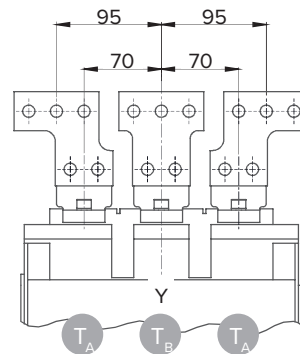
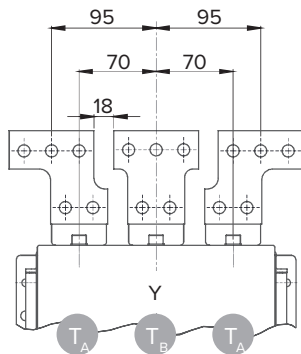

4P TEX types

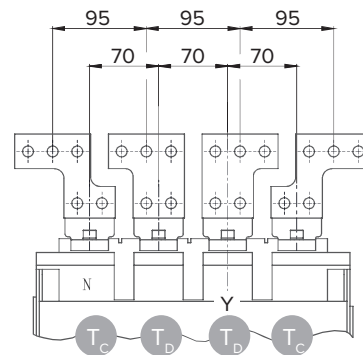
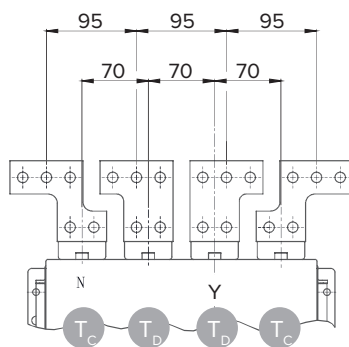

Mechanical interlocks with cables IPA

General information

For mutual interlocking of 2 or 3 (only for A25/A32/A40) ACB devices
Mechanical interlock with cable
Cable length for maximum distance of mounting positions of interlocks 2 meters
Suitable for frame sizes A16, A25/A32/A40 (A16 cannot be combined with A25/A32/A40)
Scope of delivery: 2 interlocks and 2 cables (2 ACBs version), 3 interlocks and 6 cables (3 ACBs version)
For subsequent mounting only

Mechanical diagram

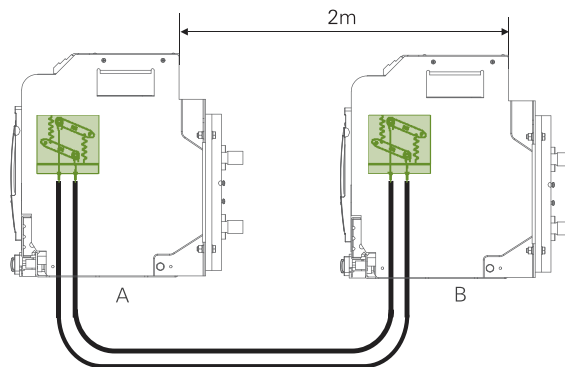

Available combinations for 2 interlocked circuit breakers

Circuit breaker A	Circuit breaker B
0	0
0	1
1	0

0: circuit breaker in OFF position ; 1: Circuit breaker in ON position

Available combinations for 3 interlocked circuit breakers

Circuit breaker A	Circuit breaker B	Circuit breaker C
0	0	0
0	0	1
0	1	0
0	1	1
1	0	0
1	0	1
1	1	0

0: circuit breaker in OFF position ; 1: Circuit breaker in ON position

Tech. Data Accessories of **SU** for **Ex9A NEC**

External neutral current transformer for Smart Units

General information

External N-pole transformer for 3P breakers in a 4W installation
 To be mounted into N conductor
 Connected to secondary terminals #28 and 29
 Cannot be combined with WEC or LEC for SU4.0 and 5.0 units

Electrical parameters

Operating current I_n	
Ex9A16	800 A, 1600 A
Ex9A25	800 A, 2500 A
Ex9A32/Ex9A40	4000 A
Cross section for N conductor	
Ex9A16	1 300 mm ²
Ex9A25	2 900 mm ²
Ex9A32/Ex9A40	2 900 mm ²
ACB secondary terminals	#28, 29

Dimensions

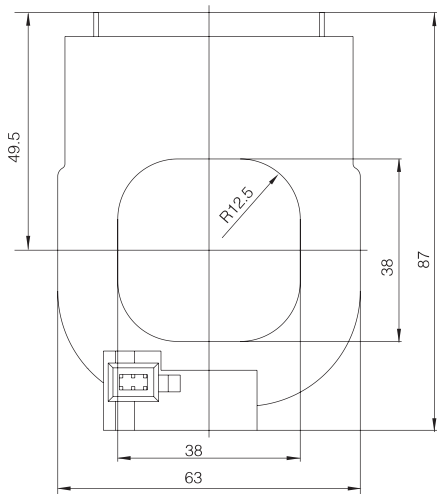

Ex9A16 400 — 1600 A

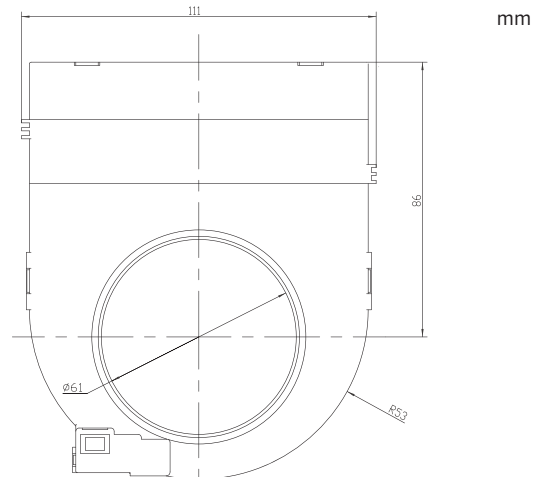

Ex9A32/40 1600 — 4000 A

Tech. Data Accessories of **SU** for **Ex9A COM**

Communication Modbus for Smart Units

General information	
For combination with H type smart units only	
Orderable as premounted only	
Connected to secondary terminals #10 (A+), 11 (B-) and 12 (GND)	
For full Modbus protocol information please visit our website or contact our technical department	

Communication parameters	
Communication protocol	Modbus-RTU
Physical layer	RS485 / RS422
Format	1 start bit, 8 data, 1 stop bit, no parity
Communication address	0 - 255
Baud rate (bit/s)	9.6k / 19.2k / 38.4k / 115.2k

Main addresses for measurement data collection					
Adress (dec)	Definition	Variable type	Unit	Attribute	Format
256	A-N Phase voltage	U_int	V	R	× 1
257	B-N Phase voltage	U_int	V	R	× 1
258	C-N Phase voltage	U_int	V	R	× 1
260	A-B Phase voltage	U_int	V	R	× 1
261	B-C Phase voltage	U_int	V	R	× 1
262	C-A Phase voltage	U_int	V	R	× 1
268	A Phase current	U_int	A	R	× 1, × 2 ^{note 1}
269	B Phase current	U_int	A	R	× 1, × 2 ^{note 1}
270	C Phase current	U_int	A	R	× 1, × 2 ^{note 1}
271	N Phase current	U_int	A	R	× 1, × 2 ^{note 1}
275	A phase current unbalance rate	U_int		R	%
276	B phase current unbalance rate	U_int		R	%
277	C phase current unbalance rate	U_int		R	%
278	Maximum current unbalance rate	U_int		R	%
280	A phase active power	Int	kW	R	×1
281	A phase reactive power	Int	kvar	R	×1
282	A phase apparent power	U_int	Kva	R	×1
283	B phase active power	Int	kW	R	×1
284	B phase reactive power	Int	kvar	R	×1
285	B phase apparent power	U_int	Kva	R	×1
286	C phase active power	Int	kW	R	×1
287	C phase reactive power	Int	kvar	R	×1
288	C phase apparent power	U_int	Kva	R	×1
289	System total active power	Int	kW	R	×1
290	System total reactive power	Int	kvar	R	×1
291	System total apparent power	U_int	Kva	R	×1
292	A phase power factor	Int		R	×0.01
293	B phase power factor	Int		R	×0.01
294	C phase power factor	Int		R	×0.01
295	System power factor	Int		R	×0.01
315	System total active power demand value	Int	kW	R	×1
316	System total reactive power demand value	Int	kvar	R	×1
317	System total apparent power demand value	Int	Kva	R	×1

Note 1: For rated current value ≥ 11 × 2, otherwise × 1

Communication Modbus for Smart Units

Main addresses for system status and history records data collection

Adress (dec)	Definition	Variable type	Unit	Attribute	Format
512	Running state(bit)	U_int		R	Check manual
513	Actual alarm(bit)	Long		R	Check manual
514					
515	H: Actual fault type (char) L: Actual fault phase (char)	U_int		R	Check manual
516	Actual fault data 0	U_int		R	Check manual
517	Actual fault data 1	U_int		R	Check manual
518	Actual fault data 2	U_int		R	Check manual
519	Actual fault data 3	U_int		R	Check manual
520	Actual fault data 4	U_int		R	Check manual
521	Actual fault data 5	U_int		R	Check manual
522	Actual fault data 6	U_int		R	Check manual
523	Actual fault data 7	U_int		R	Check manual
772	fault data 0	U_int		R	Check manual
773	fault data 1	U_int		R	Check manual
774	fault data 2	U_int		R	Check manual
775	fault data 3	U_int		R	Check manual
776	fault data 4	U_int		R	Check manual
777	fault data 5	U_int		R	Check manual
778	fault data 6	U_int		R	Check manual
779	fault data 7	U_int		R	Check manual
1028	Contact wear percent	U_int		R/W	×0.01, resettable
1029	Total contact equivalent	U_int		R	×0.01
1030	Operation times	U_int		R/W	×1, resettable
1031	total operation times	U_int		R	×1

Main addresses for protection settings data collection

Adress (dec)	Definition	Variable type	Unit	Attribute	Format
1280	I_R Long overload protection value	U_int	A	R/W	× 1, × 2 ^{note 1}
1284	I_S Short inverse time overload protection value	U_int	A	R/W	× 1, × 2 ^{note 1}
1282	I_{sd} Short constant time overload protection value	U_int	A	R/W	× 1, × 2 ^{note 1}
1283	t_{sd} Short constant time delay value	U_int	20ms	R/W	20ms × (5-20)
1285	I_i Instantaneous short circuit value	U_int	A	R/W	× 1, × 2 ^{note 1}
1286	N phase protection setting	U_int		R/W	Check manual

Note 1: For rated current value $\geq 11 \times 2$, otherwise $\times 1$

For complete information please visit our website or contact our technical support

Tech. Data Accessories of **SU** for **Ex9A ZSI**

Zone Selective Interlock ZSI for Smart Units

General information

For combination with H type smart units only

ZSI function limits the number of DO outputs from 4 contacts to 2 contacts.

Orderable as premounted only

With ZSI enabled, tripping delays even with selectivity are reduced to tripping time of instantaneous release. ZSI activation time is about 20 ms, typical total tripping time is approximately 60 ms.

ZSI electrical parameters

Total tripping time with activated ZSI	max. ca. 60 ms
Rated operating voltage of ZSI system external supply	24 V DC
Maximum output current of ZSI	48 mA
ZSI output secondary terminals	ZSI1: #15, 19 (COM) ZSI2: #16, 19 (COM)
Input current of ZSI	typically 8 mA
ZSI input secondary terminals	ZSI1: #20, 21 ZSI2: #22, 23
Contact potential	common for all DO outputs as well as with ZSI outputs, #19

Zone Selective Interlock ZSI for Smart Units

Zone Selective Interlock (ZSI)

One of the fundamental functions of protective systems is selectivity. Selectivity dramatically increases operational reliability of power distribution systems and installations. As an example see Fig. 1.

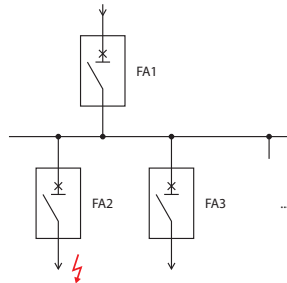

Fig. 1: Basic power distribution system.

If there were a short circuit in the downstream section of the breaker FA2, both breakers FA2 and FA1 could trip. Such action of FA1 would, however, cause unavailability of electricity for the sections of FA3 and the other parts which are not directly affected by the electrical failure. Protection and safety requirements would be fulfilled, but basic requirements for reliability of electrical supply are not kept.

A selective configuration solves this problem. Basic selectivity involves the implementation of certain time delays to the tripping times of upstream breakers (FA1 in Fig. 1). The delayed trip of FA1 would allow an electrical failure for a pre-defined time, assuring that only the downstream breaker would have time enough to trip, avoiding the unnecessary electrical disconnection of FA1 breaker and FA3 sections. This setting is available for type A breakers and it is set by parameters I_{sd} and t_{sd} among others.

An example of the traditional selectivity protection is described in Fig. 2.

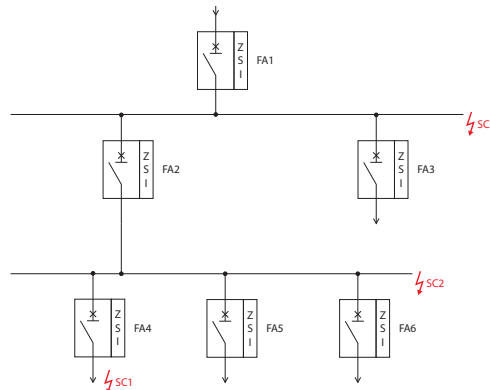

Fig. 2: Traditional selective system.

Lets observe in the Fig. 2 the theoretical event of short circuit SC1:

The situation is the same as in the previous example. To assure selectivity, tripping of FA2 must be delayed with respect to tripping time of FA4, as well as FA1 must be delayed with respect to FA2 tripping times, having a final result as described below:

$$t_{sd\ FA1} > t_{sd\ FA2} > t_{sd\ FA4 / FA5 / FA6}$$

Even though this selective configuration improves the electrical supply reliability, it would still bring imperfections to the protection of the system. For clearer understanding it will be considered (typical values):

$$t_{sd\ FA1} = 400\ ms; \quad t_{sd\ FA2\ (FA3)} = 250\ ms; \quad t_{sd\ FA4\ (FA5, FA6)} = 100\ ms;$$

Lets observe in the Fig. 2 the theoretical event of short circuit SC2:

This short circuit current must be tripped by FA2; as described previously, the parameter t_{sd} of FA2 is set to be selective with a 250 ms delay. This traditional selective configuration would allow the short circuit current flowing through the affected section for 250 ms, even if in this case the selectivity is not needed, since FA4 is not involved.

In this particular case, a big current flow would be permitted for a long period of time increasing the potential damages to the installation, and bringing no advantage over the selectivity features. Similar situation can be observed in case of SC3. The general selectivity requirement causes delay of the tripping 400 ms, but none of the downstream breakers would trip. The higher the level of selective system in an electrical short circuit failure event, the longer the tripping delay would be and bigger damages would be provoked to the electrical installation.

Zone Selective Interlock ZSI for Smart Units

Zone Selective Interlock (ZSI)

Solution of above mentioned problem can be done by means of Zone Selective Interlock (ZSI). This additional system is depicted with green colour in Fig. 3. The whole idea of ZSI comes from simple principle of sharing information about evidence of short circuit current. Circuit breakers equipped with ZSI communicate perception of short circuit via (digital) output of ZSI. This output signal is wired to ZSI input of upstream installed breaker. Several outputs can be connected in parallel to one input. ZSI module is able to initialize tripping of the breaker without respect to set t_{sd} .

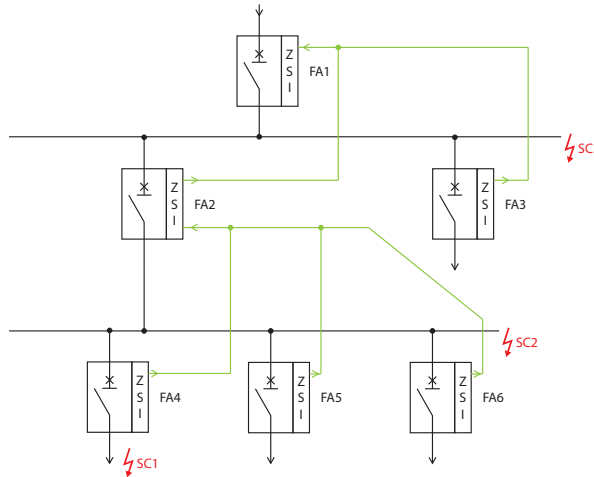

Fig. 3: Advanced selective system with ZSI feature.

In case of SC2, there is no ZSI signal from FA4 to FA2. Lack of the ZSI signal initializes the ZSI activation of tripping of FA2. As the result, FA2 trips in shorter time than $t_{sd FA2}$ which also significantly limits damage of the affected circuit.

The situation is similar in case of SC3. There is no ZSI signal from FA2 to FA1, breaker FA1 trips with $t < t_{sd FA1}$. When SC1 happens, ZSI outputs of both FA4 and FA2 signalize presence of short circuit current in their downstream circuits and neither $t_{sd FA2}$ nor $t_{sd FA1}$ is shortened. In the situation of SC2, the breaker FA1 receives ZSI information from FA2 and t_{sd} of FA1 is not affected.

The example shows that ZSI significantly reduces damages in case of short circuit in all upstream circuits.

Actual connection diagram of Ex9A

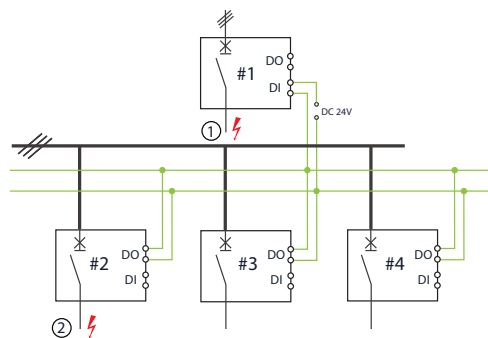

Tech. Data Accessories of **SU** for **Ex9A DO**

Digital inputs/outputs for Smart Units

General information	
For combination with H type smart units only	
Orderable as pre-mounted only	
Can be programmed as DO for alarm functions, the specific functionality can be selected in SU menu	
4 digital outputs (when ZSI functionality is not used only) or 2 digital outputs (in combination with ZSI, identical common point)	

DO electrical parameters	
Rated operating voltage of external supply	24 V DC
Maximum output current of DO	48 mA
DO secondary terminals	#15, 16, 17, 18
Contact potential	common for all DO outputs as well as with ZSI outputs, #19

Main functions map		
Issue	Description	Function name in SW
ACB trip indication	General fault indication, no further details	Fault trip
ACB alarm indication	ACB is in alarm status, right before tripping	Alarm
ACB closed indication	ACB is in closed (ON) position	Closed
ACB open indication	ACB is in closed (OFF) position	Open
Self-diagnosis	Internal diagnosis of the SU failed	Diagnosis alarm
Load monitor 1	Output for the load monitor 1	Load monitor 1
Load monitor 2	Output for the load monitor 2	Load monitor 2
Overload	Overload pre-alarm	Overload pre alarm
Trip due to overload - long	I_R overload failure	Overload fault
Trip due to overload - short	I_{sd}/I_s overload failure	Short time fault
Trip due to short circuit - inst.	I_l short circuit failure	Inst. fault
Trip due to ground fault	I_g Ground trip failure	Ground fault
Trip due to leakage	I_E Leakage trip failure	Leakage fault
Leakage alarm	I_E Leakage alarm notification	Leakage alarm
Current unbalance	Current unbalance	I unbal fault
Trip due to Neutral fault	I_N Trip due to fault in the neutral phase	Neutral fault
Undervoltage	Undervoltage	V under fault
Overvoltage	Overvoltage	V over fault
Voltage unbalance	Voltage unbalance	V unbal fault
Underfrequency	Underfrequency	F under fault
Overfrequency	Overfrequency	F over fault
Reverse power	reverse power exceeding the parameters	rP fault
Phase rotation	Phase rotation incorrect	Pr fault
Current THD	Current THD exceeds the parameters	I harmonic fault
Voltage THD	Voltage THD exceeds the parameters	V harmonic fault
MCS/HSISC	Ultrafast tripping of high-value short circuit current	MCS/HSISC fault

